

Condition number estimates for combined potential boundary integral operators in acoustic scattering

Article

Accepted Version

Chandler-Wilde, S. N., Graham, I. G., Langdon, S. and Lindner, M. (2009) Condition number estimates for combined potential boundary integral operators in acoustic scattering. *Journal of Integral Equations and Applications*, 21 (2). pp. 229-279. ISSN 0897-3962 doi: <https://doi.org/10.1216/JIE-2009-21-2-229> Available at <https://centaur.reading.ac.uk/1615/>

It is advisable to refer to the publisher's version if you intend to cite from the work. See [Guidance on citing](#).

To link to this article DOI: <http://dx.doi.org/10.1216/JIE-2009-21-2-229>

Publisher: Rocky Mountain Mathematics Consortium

All outputs in CentAUR are protected by Intellectual Property Rights law, including copyright law. Copyright and IPR is retained by the creators or other copyright holders. Terms and conditions for use of this material are defined in the [End User Agreement](#).

www.reading.ac.uk/centaur

CentAUR

Central Archive at the University of Reading

Reading's research outputs online

Condition Number Estimates for Combined Potential Boundary Integral Operators in Acoustic Scattering

SIMON N. CHANDLER-WILDE^{‡*}, IVAN G. GRAHAM^{‡†},
STEPHEN LANGDON^{*‡} and MARKO LINDNER^{*‡}

Dedicated to Rainer Kress on the occasion of his 65th birthday.

ABSTRACT. We study the classical combined field integral equation formulations for time-harmonic acoustic scattering by a sound soft bounded obstacle, namely the indirect formulation due to Brakhage-Werner/Leis/Panič, and the direct formulation associated with the names of Burton and Miller. We obtain lower and upper bounds on the condition numbers for these formulations, emphasising dependence on the frequency, the geometry of the scatterer, and the coupling parameter. Of independent interest we also obtain upper and lower bounds on the norms of two oscillatory integral operators, namely the classical acoustic single- and double-layer potential operators.

1 Introduction

In this paper we consider the classical problem of scattering of a time-harmonic acoustic wave by a bounded, sound soft obstacle occupying a compact set $\Omega \subset \mathbb{R}^d$ ($d = 2$ or 3) with Lipschitz boundary Γ . The wave propagates in the exterior domain $\Omega_e = \mathbb{R}^d \setminus \Omega$ and we suppose that the medium of propagation in Ω_e is homogeneous, isotropic and at rest, and that a time harmonic ($e^{-i\omega t}$ time dependence) pressure field u^i is incident on Ω . Denoting by $c > 0$ the speed of sound, we assume that u^i is an entire solution of the Helmholtz (or reduced wave) equation with *wave number* $k = \omega/c > 0$.

Then the problem we consider is to find the resulting time-harmonic acoustic pressure field u which satisfies the Helmholtz equation

$$\Delta u + k^2 u = 0 \quad \text{in} \quad \Omega_e \tag{1.1}$$

and the sound soft boundary condition

$$u = 0 \quad \text{on} \quad \Gamma := \partial\Omega_e, \tag{1.2}$$

*Department of Mathematics, University of Reading, Whiteknights, PO Box 220 Berkshire, RG6 6AX, UK (S.N.Chandler-Wilde@reading.ac.uk, S.Langdon@reading.ac.uk, M.Lindner@reading.ac.uk)

†Department of Mathematical Sciences, University of Bath, Bath BA2 7AY, UK (I.G.Graham@bath.ac.uk)

‡The first author gratefully acknowledges the support of a Leverhulme Trust Fellowship; the first three authors the support of Visiting Fellowships of the Isaac Newton Institute, Cambridge; the fourth author the support of a Marie Curie Fellowship of the European Commission (MEIF-CT-2005-009758).

and is such that the scattered part of the field, $u^s := u - u^i$, satisfies the Sommerfeld radiation condition

$$\frac{\partial u^s}{\partial r} - ik u^s = o(r^{-(d-1)/2}) \quad (1.3)$$

as $r := |x| \rightarrow \infty$, uniformly in $\hat{x} := x/r$. (This latter condition expresses mathematically that the scattered field u^s is outgoing at infinity; see e.g. [13]). It is well known that this problem has exactly one solution under the constraint that u and ∇u be locally square integrable; see e.g. [24].

The aim of this paper is to understand the behaviour, in the important but difficult high frequency limit $k \rightarrow \infty$, of standard reformulations of this problem in terms of second kind boundary integral equations. Let $\Phi(x, y)$ denote the standard free-space fundamental solution of the Helmholtz equation, given, in the 2D and 3D cases, by

$$\Phi(x, y) := \begin{cases} \frac{i}{4} H_0^{(1)}(k|x-y|), & d = 2, \\ \frac{e^{ik|x-y|}}{4\pi|x-y|}, & d = 3, \end{cases} \quad (1.4)$$

for $x, y \in \mathbb{R}^d$, $x \neq y$, where $H_0^{(1)}$ is the Hankel function of the first kind of order zero. It was proposed independently by Brakhage & Werner [5], Leis [22], and Panič [28], as a means to obtain an integral equation uniquely solvable at all wave numbers, to look for a solution to the scattering problem in the form of the *combined single- and double-layer potential*

$$u^s(x) := \int_{\Gamma} \frac{\partial \Phi(x, y)}{\partial \nu(y)} \varphi(y) ds(y) - i\eta \int_{\Gamma} \Phi(x, y) \varphi(y) ds(y), \quad x \in \Omega_e, \quad (1.5)$$

for some non-zero value of the *coupling parameter* $\eta \in \mathbb{R}$. (In this equation $\partial/\partial \nu(y)$ is the derivative in the normal direction, the unit normal $\nu(y)$ directed into Ω_e .) It follows from standard boundary trace results for single- and double-layer potentials that u^s , given by (1.5), satisfies the scattering problem if and only if φ satisfies a second kind boundary integral equation on Γ ; see [13] and, for the Lipschitz case, [26, 10]. This integral equation, in operator form, is

$$(I + D_k - i\eta S_k) \varphi = g, \quad (1.6)$$

where I is the identity operator, S_k and D_k are *single- and double-layer potential operators*, defined by¹

$$S_k \varphi(x) := 2 \int_{\Gamma} \Phi(x, y) \varphi(y) ds(y), \quad x \in \Gamma, \quad (1.7)$$

and

$$D_k \varphi(x) := 2 \int_{\Gamma} \frac{\partial \Phi(x, y)}{\partial \nu(y)} \varphi(y) ds(y), \quad x \in \Gamma, \quad (1.8)$$

and $g := -2u^i|_{\Gamma}$ is twice the Dirichlet data for the scattered field on Γ .

¹Our notation follows that of [13]. Some other authors omit the factor 2 in front of the integral signs in (1.7) and (1.8).

We will study (1.6) as an operator equation on the space $L^2(\Gamma)$. For every $\varphi \in L^2(\Gamma)$, the right hand sides of (1.7) and (1.8) are well-defined almost everywhere on Γ , with $D_k\varphi(x)$ understood as a Cauchy principal value, and both S_k and D_k are bounded operators on $L^2(\Gamma)$; see e.g. [26, 25, 24]. Choosing $\eta \neq 0$ ensures that (1.6) is uniquely solvable. Precisely,

$$A_{k,\eta} := I + D_k - i\eta S_k \quad (1.9)$$

is invertible as an operator on $L^2(\Gamma)$. That this is true generally for Lipschitz Γ is shown in [26, 10]; for a detailed discussion of the operator $A_{k,\eta}$ in the case when Γ is C^2 see [13]. We note further that, generalising this result, it is shown in [10] that $A_{k,\eta}$ is invertible as an operator on the Sobolev space $H^s(\Gamma)$, for $0 \leq s \leq 1$.

An alternative integral equation formulation of the scattering problem can be obtained by applications of Green's theorem. From [14, Theorem 3.12] and [24, Theorems 7.15, 9.6] it follows that, if u satisfies the scattering problem, then a form of Green's representation theorem holds, namely

$$u(x) = u^i(x) - \int_{\Gamma} \Phi(x, y) \frac{\partial u}{\partial \nu}(y) ds(y), \quad x \in \Omega_e. \quad (1.10)$$

The constraint that u and ∇u are locally square integrable in Ω_e implies that (see e.g. [24]) the normal derivative $\partial u / \partial \nu$ in this equation is well-defined as an element of the Sobolev space $H^{-1/2}(\Gamma)$. Two integral equations for $\partial u / \partial \nu$ can be obtained by taking the trace and the normal derivative, respectively, of (1.10), namely

$$S_k \frac{\partial u}{\partial \nu} = 2u^i \quad (1.11)$$

and

$$\frac{\partial u}{\partial \nu} + D'_k \frac{\partial u}{\partial \nu} = 2 \frac{\partial u^i}{\partial \nu}. \quad (1.12)$$

Here D'_k is the integral operator defined, for $\varphi \in L^2(\Gamma)$, by

$$D'_k \varphi(x) := 2 \int_{\Gamma} \frac{\partial \Phi(x, y)}{\partial \nu(x)} \varphi(y) ds(y), \quad x \in \Gamma. \quad (1.13)$$

It is well known (e.g. [13]) that the integral equations (1.11) and (1.12) fail to be uniquely solvable if $-k^2$ is an eigenvalue of the Laplacian in Ω for, respectively, homogeneous Dirichlet and Neumann boundary conditions on Γ , but that a uniquely solvable integral equation is obtained by taking an appropriate linear combination of these equations. Clearly, for every $\eta \in \mathbb{R}$ it follows from the above equations that

$$A'_{k,\eta} \frac{\partial u}{\partial \nu} = f, \quad (1.14)$$

where

$$A'_{k,\eta} := I + D'_k - i\eta S_k \quad (1.15)$$

and

$$f(x) := 2 \frac{\partial u^i}{\partial \nu}(x) - 2i\eta u^i(x), \quad x \in \Gamma.$$

Observe that (see e.g. [25] for a proof in the general Lipschitz case) D' is the transpose of D and that S is its own transpose, so that A' is the transpose of A in the same sense, namely that

$$(\phi, A_{k,\eta}\psi)_\Gamma = (A'_{k,\eta}\phi, \psi)_\Gamma, \quad \text{for } \phi \in L^2(\Gamma), \psi \in L^2(\Gamma), \quad (1.16)$$

where $(\phi, \psi)_\Gamma := \int_\Gamma \phi\psi ds$. This identity implies that $A'_{k,\eta}$ is also a bounded operator on $L^2(\Gamma)$ with

$$\|A'_{k,\eta}\| = \|A_{k,\eta}\|, \quad (1.17)$$

and that $A'_{k,\eta}$ is invertible (as an operator on $L^2(\Gamma)$) if and only if $A_{k,\eta}$ is invertible. Moreover, if they are both invertible, it holds that

$$\|A'_{k,\eta}{}^{-1}\| = \|A_{k,\eta}^{-1}\|. \quad (1.18)$$

In particular, $A_{k,\eta}$ and also $A'_{k,\eta}$ is invertible and (1.18) holds for $\eta \neq 0$. In fact (see [10], [11, §4]), for $\eta \neq 0$, $A'_{k,\eta}$ is invertible as an operator on the Sobolev space $H^s(\Gamma)$, for $-1 \leq s \leq 0$. Thus, noting that $f \in L^2(\Gamma)$, (1.14) has exactly one solution in $H^{-1/2}(\Gamma)$ and this solution is in $L^2(\Gamma)$.

Our aim in this paper is to study the conditioning of the two standard integral equation formulations, (1.6) and (1.14), of the exterior sound soft scattering problem. Specifically we are interested in upper and lower bounds on the (identical) condition numbers of $A_{k,\eta}$ and $A'_{k,\eta}$, given by

$$\text{cond } A'_{k,\eta} = \text{cond } A_{k,\eta} = \|A_{k,\eta}\| \|A_{k,\eta}^{-1}\|,$$

and so we are interested in upper and lower bounds on the norms $\|A_{k,\eta}\| = \|A'_{k,\eta}\|$ and $\|A_{k,\eta}^{-1}\| = \|A'_{k,\eta}{}^{-1}\|$. Our emphasis is on understanding the dependence on the wave number k , especially in the limit $k \rightarrow \infty$, and on the coupling parameter η , and on exploring the influence of the shape of Γ .

The questions we address have had some previous attention, starting with the work of Kress and Spassov [19] and Kress [18] (and see [2, 3, 17, 8, 15, 4, 11]); we will summarise these previous results in the next section. But we note that, with the exception of recent bounds in [15, 4, 11], rigorous estimates valid in the limit as $k \rightarrow \infty$ have not been obtained. Moreover, research to date has focussed almost entirely on the case when Γ is a circle or sphere where Fourier analysis methods are possible. The estimates we will derive in this paper will address these gaps in the literature and show that the behaviour of $\text{cond } A_{k,\eta}$ as a function of k depends strongly, and in a subtle way, on the geometry of Γ .

The plan of the rest of this paper is as follows. As already mentioned, in §2 we discuss previous work, in particular what is known about $\|S_k\|$, $\|D_k\|$, $\|A_{k,\eta}\|$, and $\|A_{k,\eta}^{-1}\|$ and their dependence on k and η in the special case of a circle and sphere. We also recall a recent and rather sharp upper bound on $\|A_{k,\eta}^{-1}\|$ which applies (in 2D and 3D) whenever Γ is Lipschitz, piecewise smooth, and starlike. In particular, we point out that this bound implies that commonly recommended choices of η , e.g. [18]

$$\eta = \max\left(\frac{1}{2R_0}, k\right),$$

where $2R_0$ is the diameter of Γ , have the desirable property that $\|A_{k,\eta}^{-1}\| \leq C$ for $k > 0$, where the constant C depends (in an explicit way spelled out in §2) only on the shape of Γ .

In §3 we obtain what look at first sight like fairly crude upper bounds on $\|S_k\|$ and $\|D_k\|$ (and hence obtain, by the triangle inequality, upper bounds on $\|A_{k,\eta}\|$) for general Lipschitz domains in 2D and 3D. These bounds are complemented in §4 by a number of lower bounds on $\|S_k\|$, $\|D_k\|$, and $\|A_{k,\eta}\|$, mostly for the 2D case. One message from these lower bounds is that, at least in the 2D case, the simple upper bounds in §3 turn out to be rather sharp in their dependence on k . Precisely, there exist Lipschitz boundaries Γ for which the ratio of the upper to the lower bound: (i) remains bounded as $k \rightarrow \infty$ in the case of $\|S_k\|$; (ii) increases arbitrarily slowly as $k \rightarrow \infty$ in the case of $\|D_k\|$. A second message from these lower bounds is that the behaviours of $\|S_k\|$ and $\|D_k\|$ as $k \rightarrow \infty$ depend in subtle (and different) ways on the geometry of Γ .

In §5 we analyse a particular example of a non-starlike domain. While the results in §2 show that, with an appropriate choice of η , $\|A_{k,\eta}^{-1}\| = O(1)$ as $k \rightarrow \infty$ when Γ is starlike, in §5 we prove that $\|A_{k,\eta}^{-1}\|$, with the same choice of η , can grow as fast as $k^{9/10}$ as $k \rightarrow \infty$ when the domain is non-starlike.

In §6 we summarise the results of sections 2-5 and examine their implications for the condition number of $A_{k,\eta}$. The main message here is that conditioning in the limit as $k \rightarrow \infty$ depends strongly on the geometry of Γ , and that conditioning can be much worse than in the case of a circle/sphere. For example, in 2D, and with the usual choice $\eta = k$, our conclusion is that $\text{cond } A_{k,\eta} = \text{cond } A'_{k,\eta}$ grows like $k^{1/3}$ for a circle, like $k^{1/2}$ for a starlike polygon, and at least as fast as $k^{7/5}$ for the trapping domains studied in §5. We recommend that readers more interested in the results and their implications for conditioning than in the details of the proofs read §6 before the rest of the paper.

We finish this introduction by introducing some notation and properties relating to Bessel functions that we shall use throughout. For $m \in \mathbb{N}_0 := \mathbb{N} \cup \{0\}$ let J_m and Y_m denote the Bessel functions of order m of the first and second kinds, respectively, and let $H_m^{(1)} := J_m + iY_m$ denote the Hankel function of the first kind of order m . (Our notations and definitions follow [1].) Moreover, for $t > 0$ let

$$M_m(t) := |H_m^{(1)}(t)|. \quad (1.19)$$

We will use throughout the fact that $M_m(t)$ is decreasing as t increases [34, §13.74].

An informative integral representation for $H_0^{(1)}$ is [27]

$$H_0^{(1)}(t) = -\frac{2i}{\pi} e^{it} \int_0^\infty \frac{e^{-rt}}{r^{1/2}(r-2i)^{1/2}} dr, \quad t > 0, \quad (1.20)$$

with $\Re(r-2i)^{1/2} > 0$ for $r > 0$, where \Re denotes the real part of a complex number. This representation implies, since $H_1^{(1)} = -H_0^{(1)'}$, that

$$H_1^{(1)}(t) = \frac{2i}{\pi} e^{it} \int_0^\infty \frac{(i-r)e^{-rt}}{r^{1/2}(r-2i)^{1/2}} dr, \quad t > 0. \quad (1.21)$$

From these representations follow the bounds

$$M_0(t) \leq \frac{2}{\pi} \int_0^\infty \frac{e^{-rt}}{(2r)^{1/2}} dr = \sqrt{\frac{2}{\pi t}}, \quad t > 0, \quad (1.22)$$

and

$$M_1(t) \leq \frac{2}{\pi} \int_0^\infty \left(\frac{1}{(2r)^{1/2}} + 1 \right) e^{-rt} dr = \sqrt{\frac{2}{\pi t}} + \frac{2}{\pi t}, \quad t > 0. \quad (1.23)$$

From (1.21) we deduce moreover that, for $t > 0$,

$$\begin{aligned} e^{-it} H_1^{(1)}(t) + \frac{2i}{\pi t} &= \frac{2i}{\pi} \int_0^\infty \left(\frac{(i-r)}{r^{1/2}(r-2i)^{1/2}} + 1 \right) e^{-rt} dr \\ &= \frac{2i}{\pi} \int_0^\infty \frac{e^{-rt}}{r^{1/2}(r-2i)^{1/2}(r^{1/2}(r-2i)^{1/2} + r-i)} dr. \end{aligned}$$

From this identity, noting that $\Im(r^{1/2}(r-2i)^{1/2} + r-i) \leq -1$, it follows that

$$\left| e^{-it} H_1^{(1)}(t) + \frac{2i}{\pi t} \right| \leq \frac{2}{\pi} \int_0^\infty \frac{e^{-rt}}{(2r)^{1/2}} dr = \sqrt{\frac{2}{\pi t}}, \quad t > 0. \quad (1.24)$$

The bounds (1.22), (1.23) and (1.24) are all sharp for large t since (e.g. [1])

$$H_m^{(1)}(t) = \sqrt{\frac{2}{\pi t}} \exp(i(t - \pi/4 - m\pi/2)) + O(t^{-3/2}), \quad \text{as } t \rightarrow \infty, \quad (1.25)$$

and it holds similarly [1] that

$$H_m^{(1)'}(t) = \sqrt{\frac{2}{\pi t}} \exp(i(t + \pi/4 - m\pi/2)) + O(t^{-3/2}), \quad \text{as } t \rightarrow \infty. \quad (1.26)$$

It follows from (1.24) that (1.23) is also sharp for small t .

We will find the notation

$$\Psi_m(t) := e^{-it} H_m^{(1)}(t), \quad t > 0, \quad (1.27)$$

useful. Clearly $|\Psi_m(t)| \leq M_m(t)$ and it follows from (1.25) and (1.26) that

$$\Psi_m(t) = \sqrt{\frac{2}{\pi t}} \exp(-i(\pi/4 + m\pi/2)) + O(t^{-3/2}), \quad \Psi_m'(t) = O(t^{-3/2}), \quad \text{as } t \rightarrow \infty. \quad (1.28)$$

For $m = 0$ and 1 these asymptotics can alternatively be deduced by applications of Watson's lemma to (1.20) and (1.21).

2 Previous results and the case of a circle or sphere

As noted in the introduction, previous studies of the conditioning and spectral properties of $A_{k,\eta}$ or $A'_{k,\eta}$ have focussed on the special case of circular and spherical Γ

[19, 18, 2, 3, 17, 8, 15, 4]. We will summarise the results of these studies in this section, and also recent bounds on $\|A_{k,\eta}^{-1}\|$ for more general geometries [11]. We note that some of the above papers (e.g. [2, 3]) also make a similar study for the circle/sphere of the conditioning of the Burton and Miller integral equation for the acoustic sound-hard (Neumann) scattering problem [9], or for electromagnetic combined field integral equations (e.g. [18]). In other related work, Warnick and Chew [33, 32, 31] study the conditioning of matrix discretisations of the first kind integral equation (1.11) via an approximate theoretical analysis and numerical experiments, obtaining simple explicit approximate upper and lower bounds for the condition number as a function of k and the discretisation step size for several canonical 2D geometries (a circle, crack and two parallel cracks) [31, Table 2].

In the case of circular and spherical Γ a very complete theory of conditioning is possible, due to the fact that $A_{k,\eta}$ and $A'_{k,\eta}$ operate diagonally in the basis of trigonometric polynomials ($d = 2$) or spherical harmonics ($d = 3$). The analysis is further simplified by the fact that $D'_k = D_k$ and so $A'_{k,\eta} = A_{k,\eta}$.

Suppose Γ is the unit circle, with parametrisation $\boldsymbol{\gamma}(t) = (\cos t, \sin t)$. With this parametrisation $L^2(\Gamma)$ is isometrically isomorphic to $L^2[0, 2\pi]$. We can write any $\varphi \in L^2[0, 2\pi] = L^2(\Gamma)$ as

$$\varphi(t) = \frac{1}{2\pi} \sum_{m \in \mathbb{Z}} \widehat{\varphi}(m) \exp(imt), \quad \text{where} \quad \widehat{\varphi}(m) := \int_0^{2\pi} \varphi(t) \exp(-imt) dt,$$

in which case the L^2 -inner product and norm are given by $(\varphi, \psi) = \frac{1}{2\pi} \sum_{m \in \mathbb{Z}} \widehat{\varphi}(m) \overline{\widehat{\psi}(m)}$ and $\|\varphi\|^2 = \frac{1}{2\pi} \sum_{m \in \mathbb{Z}} |\widehat{\varphi}(m)|^2$. Then (see [18, equation (4.4)] or [15, Lemma 1]), we have the Fourier representation:

$$A_{k,\eta}\varphi(t) = \frac{1}{2\pi} \sum_{m \in \mathbb{Z}} \lambda_{k,\eta}(m) \widehat{\varphi}(m) \exp(imt) \quad \text{with} \quad \lambda_{k,\eta}(m) = \pi H_{|m|}^{(1)}(k) [ikJ'_{|m|}(k) + \eta J_{|m|}(k)]. \quad (2.1)$$

Note that $\lambda_{k,\eta}(m)$ is the eigenvalue of $A_{k,\eta}$ corresponding to the eigenfunction $\exp(\pm imt)$. As argued in [18], since the eigenfunctions $\exp(imt)$, $m \in \mathbb{Z}$, are a complete orthonormal system in $L^2[0, 2\pi] = L^2(\Gamma)$, it holds that

$$\|A_{k,\eta}\| = \sup_{m \in \mathbb{N}_0} |\lambda_{k,\eta}(m)|, \quad \|A_{k,\eta}^{-1}\| = \left(\inf_{m \in \mathbb{N}_0} |\lambda_{k,\eta}(m)| \right)^{-1}, \quad (2.2)$$

so that

$$\text{cond } A_{k,\eta} = \frac{\sup_{m \in \mathbb{N}_0} |\lambda_{k,\eta}(m)|}{\inf_{m \in \mathbb{N}_0} |\lambda_{k,\eta}(m)|}. \quad (2.3)$$

The problem $A_{k,\eta}\varphi = g$, with $g \in L^2(\Gamma) = L^2[0, 2\pi]$, can be recast in variational form as $a_{k,\eta}(\varphi, \psi) = (g, \psi)$, where the sesquilinear form $a_{k,\eta}$ is given by

$$a_{k,\eta}(\varphi, \psi) = (A_{k,\eta}\varphi, \psi) = \frac{1}{2\pi} \sum_{m \in \mathbb{Z}} \lambda_{k,\eta}(m) \widehat{\varphi}(m) \overline{\widehat{\psi}(m)}. \quad (2.4)$$

For $\varphi \in L^2(\Gamma)$,

$$\Re(a_{k,\eta}(\varphi, \varphi)) = \frac{1}{2\pi} \sum_{m \in \mathbb{Z}} \Re(\lambda_{k,\eta}(m)) |\widehat{\varphi}(m)|^2 \geq \alpha_{k,\eta} \|\varphi\|^2, \quad (2.5)$$

where

$$\alpha_{k,\eta} = \inf_{m \in \mathbb{N}_0} \Re(\lambda_{k,\eta}(m)). \quad (2.6)$$

The recent paper [15] obtains rigorous upper bounds on $\|a_{k,\eta}\| = \|A_{k,\eta}\| = \sup_{m \in \mathbb{N}_0} |\lambda_{k,\eta}(m)|$ and lower bounds on $\alpha_{k,\eta}$. The results are worked out explicitly for the case $\eta = k$ (previously proposed as optimal for conditioning for the unit circle when $k \geq 1$ in e.g. [19, 2, 3]) and are that, for all sufficiently large k ,

$$\|a_{k,k}\| = \|A_{k,k}\| \leq Ck^{1/3}, \quad (2.7)$$

$$\alpha_{k,k} \geq 1, \quad (2.8)$$

with C a constant independent of k . Since $\|A_{k,\eta}^{-1}\| \leq \alpha_{k,\eta}^{-1}$, (2.8) implies that

$$\|A_{k,k}^{-1}\| \leq 1, \quad (2.9)$$

for all sufficiently large k . The bound (2.8) is very technical to prove whereas the result (2.7) is somewhat easier, requiring only upper bounds for certain combinations of Bessel functions which are readily available in [1].

For the case $d = 3$, when Γ is a sphere of unit radius, a similar analysis applies, based on the fact that the integral operators on the sphere are diagonal operators in the space of spherical harmonics. The corresponding expression for the symbol $\lambda_{k,\eta}$ is

$$\lambda_{k,\eta}(m) = ikh_m^{(1)}(kj'_m(k) + i\eta j_m(k)), \quad (2.10)$$

where j_m and $h_m^{(1)}$ are the spherical Bessel and Hankel functions respectively. This formula can be found, for example, in [18, 17] – see also [8]. The formulae (2.2) and (2.3) hold also in the 3D case [18], with $\lambda_{k,\eta}$ given by (2.10). It is shown in [15] that, for all sufficiently large k , (2.7) holds also in the 3D case and that, for every $C' > 1$, $\alpha_{k,k} \geq C'$ for all sufficiently large k . This implies that

$$\|A_{k,k}^{-1}\| \leq \frac{1}{C'}, \quad (2.11)$$

for all sufficiently large k .

It is important to note that (2.7) was proved previously in the 3D case in the thesis of Giebermann [17]. Further, the conjecture $\alpha_{k,\eta} \geq \min(1, 2|\eta|/k)$ was made in [17], backed up by numerical experiments and some asymptotic analysis of special cases. Related results are in [8]. Recently a similar analysis to that in [17, 15], by Banjai and Sauter [4], has led to a more refined and flexible upper bound on $A_{k,\eta}$ than (2.7) in the 3D case. They show that, for all sufficiently large k ,

$$\|D_k\| \leq C, \quad \|S_k\| \leq Ck^{-2/3}, \quad (2.12)$$

for some constant C independent of k , which implies that

$$\|A_{k,\eta}\| = \|I + D_k - i\eta S_k\| \leq 1 + \|D_k\| + |\eta| \cdot \|S_k\| \quad (2.13)$$

$$\leq 1 + C(1 + |\eta|k^{-2/3}). \quad (2.14)$$

The choice $|\eta| = k$ yields the same estimate as (2.7), whereas the choice $|\eta| = k^{2/3}$ yields a k -independent bound for $\|A_{k,\eta}\|$. This is employed in [4] to obtain improved

error estimates for conventional Galerkin boundary element approximations of the combined potential equation.

We remark that (2.8), which establishes coercivity for the combined potential operator sesquilinear form $a_{k,k}$ for all sufficiently large k , moreover with a coercivity constant independent of k , is of more use for the analysis of numerical methods than the bounds on condition number implied by (2.7), (2.9), and (2.11). Since bounds on $\|a_{k,\eta}\|$ combined with coercivity ensure the stability and convergence of any Galerkin scheme, this can be used to prove theorems about the convergence of special Galerkin boundary integral equation methods for high frequency scattering problems. This was the chief motivation for the analysis in [15].

Using completely different techniques (Rellich-type identities and subtle properties of radiating solutions of the Helmholtz equation), bounds on $\|A_{k,\eta}^{-1}\|$ have also been obtained recently in [11]. These apply for a general class of geometries, namely whenever Ω is simply-connected, piecewise smooth and starlike. For the rest of this section we assume, without loss of generality, that the origin lies in Ω ($0 \in \Omega$). Then the class of domains studied in [11] are those satisfying the following assumption (Assumption 3 in [11]):

Assumption 2.1 Γ is Lipschitz and is C^2 in a neighbourhood of almost every $x \in \Gamma$. Further

$$\delta_- := \operatorname{ess\,inf}_{x \in \Gamma} x \cdot \nu(x) > 0.$$

Note that Assumption 2.1 holds, for example, if Ω is a starlike polyhedron (and $0 \in \Omega$), with δ_- the distance from the origin to the nearest side of Γ .

Define

$$R_0 := \sup_{x \in \Gamma} |x|, \quad \delta_+ := \operatorname{ess\,sup}_{x \in \Gamma} x \cdot \nu(x), \quad \delta^* := \operatorname{ess\,sup}_{x \in \Gamma} |x - (x \cdot \nu(x))\nu(x)|.$$

Then a main result in [11] is the following:

Theorem 2.2 Suppose that Assumption 2.1 holds and $\eta \in \mathbb{R} \setminus \{0\}$. Then

$$\|A_{k,\eta}^{-1}\| = \|A'_{k,\eta}{}^{-1}\| \leq B \tag{2.15}$$

where

$$B := \frac{1}{2} + \left[\left(\frac{\delta_+}{\delta_-} + \frac{4\delta^{*2}}{\delta_-^2} \right) \left[\frac{\delta_+}{\delta_-} \left(\frac{k^2}{\eta^2} + 1 \right) + \frac{d-2}{\delta_-|\eta|} + \frac{\delta^{*2}}{\delta_-^2} \right] + \frac{(1+2kR_0)^2}{2\delta_-^2\eta^2} \right]^{1/2}.$$

To understand this expression for B , suppose first that Γ is a circle or sphere, i.e. $\Gamma = \{x : |x| = R_0\}$. Then $\delta_- = \delta_+ = R_0$ and $\delta^* = 0$ so

$$B = B_0 := \frac{1}{2} + \left[1 + \frac{k^2}{\eta^2} + \frac{d-2}{R_0|\eta|} + \frac{(1+2kR_0)^2}{2R_0^2\eta^2} \right]^{1/2}. \tag{2.16}$$

In the general case, since $\delta_- \leq \delta_+ \leq R_0$ and $0 \leq \delta^* \leq R_0$, it holds that $B \geq B_0$. Note that the expression B blows up if $k/|\eta| \rightarrow \infty$ or if $\delta_+/\delta_- \rightarrow \infty$, or if $\delta_-|\eta| \rightarrow 0$, uniformly with respect to the values of other variables.

A number of studies of the circle/sphere case have been concerned with making a choice of η which is optimal in terms of minimising the condition number (2.3). In particular, based on low frequency asymptotics and numerical calculations, the optimal choice of η proposed in [18] is

$$\eta = \max\left(\frac{1}{2R_0}, k\right) \quad (2.17)$$

for the 3D case (and see [2, 3] for some further evidence supporting this choice). Providing evidence that this is in fact a good choice whenever Γ is starlike in the sense of Assumption 2.1, Theorem 2.2 shows that if η is chosen so that

$$\max(l_1 R_0^{-1}, l_2 k) \leq |\eta| \leq \max(u_1 R_0^{-1}, u_2 k), \quad (2.18)$$

for some positive constants l_1, l_2, u_1 , and u_2 , then, for some constant $C > 0$, $\|A_{k,\eta}^{-1}\| = \|A'_{k,\eta}{}^{-1}\| \leq C$ for $k > 0$. For example, choosing

$$\eta = R_0^{-1} + k, \quad (2.19)$$

which satisfies (2.18) with $l_1 = l_2 = 1$ and $u_1 = u_2 = 2$, defining $\theta := R_0/\delta_-$, and noting that $\delta_+/\delta_- \leq \theta$, $\delta^*/\delta_- \leq \theta$, we see that Theorem 2.2 implies that

$$\|A_{k,\eta}^{-1}\| = \|A'_{k,\eta}{}^{-1}\| \leq B \leq \frac{1}{2} + \theta[2 + (1 + 4\theta)(d + \theta)]. \quad (2.20)$$

Based on computational experience, Bruno and Kunyansky [6, 7] recommend the choice $\eta = \max(6T^{-1}, k/\pi)$, where T is the diameter of the obstacle, which satisfies (2.18), this formula chosen on the basis of minimising the number of GMRES iterations in an iterative solver.

3 Upper bounds on $\|S_k\|$, $\|D_k\|$ and $\|A_{k,\eta}\|$ in the general Lipschitz case

In this section we derive upper bounds on $\|A_{k,\eta}\|$ from (1.9) which are explicit in their dependence on the wave number k and the coupling parameter η , for both the 2D and the 3D case. To do this, we use the triangle inequality (2.13) together with upper bounds on the norms $\|S_k\|$ and $\|D_k\|$. The only geometric restriction on our scatterer $\Omega \subset \mathbb{R}^d$ for now is our assumption throughout that it is Lipschitz, by which we mean [24, §3] that Ω is compact and there exist finite families $\{W_i\}$, $\{M_i\}$, $\{f_i\}$ and $\{\Omega_i\}$ such that

- (i) The family $\{W_i \subset \mathbb{R}^d\}$ is a finite open cover of the boundary $\Gamma = \partial\Omega$;
- (ii) Every M_i is a positive real number and every $f_i : \mathbb{R}^{d-1} \rightarrow \mathbb{R}$ is a Lipschitz continuous function with $|f_i(\xi) - f_i(\eta)| \leq M_i \|\xi - \eta\|$ for all $\xi, \eta \in \mathbb{R}^{d-1}$;
- (iii) Every $\Omega_i \subset \mathbb{R}^d$ can be transformed, by a suitable rotation and translation, into the hypograph $\{(\xi, z) \in \mathbb{R}^{d-1} \times \mathbb{R} : z \leq f_i(\xi)\}$ of the corresponding f_i ;

(iv) Ω and Ω_i have the same intersection with W_i , for each i .

It is clear that the finite family of values $\{M_i\}$ can be replaced by one global value $M = \max_i M_i$. Moreover, for each $x \in \Gamma$ and all i in our finite index set, let $\varepsilon(x, i)$ be the supremum of all $\varepsilon > 0$ for which the open Euclidean ε -neighbourhood $U_\varepsilon(x)$ of x is contained in W_i (with $\varepsilon(x, i) = 0$ if $x \notin W_i$). Now put $\varepsilon(x) = \max_i \varepsilon(x, i)$ and note that $x \mapsto \varepsilon(x)$ is a continuous function over the compact set Γ ; so it attains its minimum $\varepsilon_0 := \varepsilon(x_0)$ at some point $x_0 \in \Gamma$, which shows that $\varepsilon_0 > 0$ since x_0 is covered by (and therefore an interior point of) at least one W_i . As a consequence, we get that, for each $x \in \Gamma$, $U_{\varepsilon_0}(x)$ is contained in at least one W_i . This shows the following:

Lemma 3.1 *For every Lipschitz domain Ω , there are constants $\varepsilon > 0$ and $M > 0$ such that, for every $x \in \Gamma = \partial\Omega$, there is a Lipschitz continuous function $f_x : \mathbb{R}^{d-1} \rightarrow \mathbb{R}$ with Lipschitz constant M and an appropriate rotation and translation Ω_x of the hypograph $\{(\xi, z) \in \mathbb{R}^{d-1} \times \mathbb{R} : z \leq f_x(\xi)\}$ of f_x with $\Omega \cap U_\varepsilon(x) = \Omega_x \cap U_\varepsilon(x)$.*

Throughout the paper we will say that $\Gamma = \partial\Omega$ is Lipschitz if Ω is a Lipschitz domain.

Lemma 3.2 (cf. [30]) *Let $\Omega \subset \mathbb{R}^d$ be a Lipschitz domain. Then the following holds.*

a) *If $d = 2$ then*

$$\sup_{x \in \Gamma} \int_{\Gamma} \frac{1}{\sqrt{|x-y|}} ds(y) < \infty.$$

b) *If $d = 3$ then*

$$\sup_{x \in \Gamma} \int_{\Gamma} \frac{1}{|x-y|} ds(y) < \infty.$$

Proof. This follows easily from Lemma 3.1 by splitting the integrals over Γ into one weakly singular integral over $\Gamma \cap U_\varepsilon(x)$ and one integral over the (bounded) rest of Γ . ■

Our main strategy in computing bounds on $\|S_k\|$ and $\|D_k\|$ is the following. Let

$$T\varphi(x) = \int_{\Gamma} \kappa(x, y) \varphi(y) ds(y), \quad x \in \Gamma, \quad (3.1)$$

denote an integral operator with a suitable kernel function $\kappa(\cdot, \cdot)$ on $\Gamma \times \Gamma$. To show that T is bounded and to estimate its operator norm as a mapping $L^2(\Gamma) \rightarrow L^2(\Gamma)$, we show that it is bounded both as a mapping $L^1(\Gamma) \rightarrow L^1(\Gamma)$ and $L^\infty(\Gamma) \rightarrow L^\infty(\Gamma)$ and use the Riesz-Thorin interpolation theorem (e.g. [23, Theorem 2.b.14]), which says that

$$\|T\| := \|T\|_{L^2 \rightarrow L^2} \leq \|T\|_{L^1 \rightarrow L^1}^{1/2} \cdot \|T\|_{L^\infty \rightarrow L^\infty}^{1/2} \quad (3.2)$$

holds, where the two norms on the right are explicitly given by (e.g. [21])

$$\|T\|_{L^1 \rightarrow L^1} = \operatorname{ess\,sup}_{y \in \Gamma} \int_{\Gamma} |\kappa(x, y)| ds(x), \quad \|T\|_{L^\infty \rightarrow L^\infty} = \operatorname{ess\,sup}_{x \in \Gamma} \int_{\Gamma} |\kappa(x, y)| ds(y).$$

In particular, if $|\kappa(x, y)| = |\kappa(y, x)|$ for all $x, y \in \Gamma$, then $\|T\|_{L^1 \rightarrow L^1}$ and $\|T\|_{L^\infty \rightarrow L^\infty}$ have the same value, and (3.2) simplifies to

$$\|T\| \leq \|T\|_{L^1 \rightarrow L^1} = \|T\|_{L^\infty \rightarrow L^\infty}. \quad (3.3)$$

More generally, if $\tilde{\kappa}(x, y) = \tilde{\kappa}(y, x)$ and $|\kappa(x, y)| \leq \tilde{\kappa}(x, y)$, for all $x, y \in \Gamma$, then it follows from (3.2) that

$$\|T\| \leq \operatorname{ess\,sup}_{x \in \Gamma} \int_{\Gamma} \tilde{\kappa}(x, y) \, ds(y). \quad (3.4)$$

From (1.4) and (1.7) the kernel of the single-layer potential operator S_k in 2D is $\kappa(x, y) = \frac{i}{2} H_0^{(1)}(k|x - y|)$. Clearly, $\kappa(x, y) = \kappa(y, x)$ for all $x, y \in \Gamma$, and therefore the bound (3.3) applies. From (3.3) and (1.22) we see that

$$\|S_k\| \leq \operatorname{ess\,sup}_{x \in \Gamma} \int_{\Gamma} \left| \frac{i}{2} H_0^{(1)}(k|x - y|) \right| \, ds(y) \leq \frac{C}{\sqrt{k}} \quad (3.5)$$

where

$$C := \sqrt{\frac{1}{2\pi}} \operatorname{ess\,sup}_{x \in \Gamma} \int_{\Gamma} \frac{1}{\sqrt{|x - y|}} \, ds(y) < \infty \quad (3.6)$$

by Lemma 3.2.

In 3D, the single-layer potential S_k is an integral operator (3.1) with kernel

$$\kappa(x, y) = \frac{e^{ik|x-y|}}{2\pi|x-y|}, \quad x, y \in \Gamma.$$

As in 2D, the kernel function $\kappa(\cdot, \cdot)$ is symmetric, and therefore the norm bound (3.3) applies. Consequently,

$$\|S_k\| \leq \operatorname{ess\,sup}_{x \in \Gamma} \int_{\Gamma} \left| \frac{e^{ik|x-y|}}{2\pi|x-y|} \right| \, ds(y) = \frac{1}{2\pi} \operatorname{ess\,sup}_{x \in \Gamma} \int_{\Gamma} \frac{ds(y)}{|x-y|} < \infty, \quad (3.7)$$

by Lemma 3.2.

We see that we have shown, in (3.5) and (3.7), the following theorem:

Theorem 3.3 *If Γ is Lipschitz then there exists a positive constant c , dependent only on Γ , such that*

$$\|S_k\| \leq ck^{(d-3)/2}$$

for $k > 0$.

The double-layer potential D_k in 2D is an integral operator (3.1) with kernel

$$2 \frac{\partial \Phi(x, y)}{\partial \nu(y)} = \frac{i}{2} k H_1^{(1)}(k|x - y|) \frac{x - y}{|x - y|} \cdot \nu(y), \quad x, y \in \Gamma. \quad (3.8)$$

Noting that, for $t > 0$, $|e^{it} - 1| = 2|\sin(t/2)| \leq \min(t, 2) \leq \sqrt{2t}$ and using (1.24) we see that, for $t > 0$,

$$\left| H_1^{(1)}(t) + \frac{2i}{\pi t} \right| \leq \left| H_1^{(1)}(t) + \frac{2ie^{it}}{\pi t} \right| + \frac{2}{\pi t} |e^{it} - 1| \leq \left(\sqrt{\frac{2}{\pi}} + \frac{2\sqrt{2}}{\pi} \right) \frac{1}{\sqrt{t}}. \quad (3.9)$$

Let D_0 denote the double-layer potential operator for the Laplace case, whose kernel is given by taking the limit $k \rightarrow 0$ in (3.8), i.e. by replacing $ikH_1^{(1)}(k|x-y)$ by $2/(\pi|x-y|)$ in (3.8). Since D_0 is independent of k and a bounded operator whenever Ω is Lipschitz (e.g. [25]), and since $\|D_k\| \leq \|D_k - D_0\| + \|D_0\|$, it remains to bound $\|D_k - D_0\|$. The difference $D_k - D_0$ is an integral operator (3.1) with kernel

$$\kappa(x, y) = \left(\frac{i}{2}k H_1^{(1)}(k|x-y|) - \frac{1}{\pi|x-y|} \right) \frac{x-y}{|x-y|} \cdot \nu(y), \quad x, y \in \Gamma.$$

Using (3.9) we see that $|\kappa(x, y)| \leq \tilde{\kappa}(x, y)$, where

$$\tilde{\kappa}(x, y) := \left(\sqrt{\frac{2}{\pi}} + \frac{2\sqrt{2}}{\pi} \right) \frac{k^{1/2}}{2|x-y|^{1/2}}.$$

Hence and from (3.4) it follows that $\|D_k - D_0\| \leq C_1 k^{1/2}$, with

$$C_1 := \frac{1}{2} \left(\sqrt{\frac{2}{\pi}} + \frac{2\sqrt{2}}{\pi} \right) \operatorname{ess\,sup}_{x \in \Gamma} \int_{\Gamma} \frac{1}{\sqrt{|x-y|}} ds(y) < \infty$$

by Lemma 3.2. Thus

$$\|D_k\| \leq \|D_k - D_0\| + \|D_0\| \leq C_1 \sqrt{k} + C_2 \quad (3.10)$$

with $C_2 := \|D_0\|$.

In 3D the double-layer potential D_k is an integral operator (3.1) with kernel

$$2 \frac{\partial \Phi(x, y)}{\partial \nu(y)} = \frac{e^{ik|x-y|}}{2\pi|x-y|^3} (ik|x-y| - 1) (x-y) \cdot \nu(y), \quad x, y \in \Gamma.$$

As in 2D, the operator D_0 is bounded on $L^2(\Gamma)$ whenever Ω is Lipschitz (e.g. [25]). So it again remains to bound $\|D_k - D_0\|$. The difference $D_k - D_0$ is an integral operator (3.1) with kernel

$$\kappa(x, y) = \frac{1}{2\pi|x-y|^3} (e^{ik|x-y|}(ik|x-y| - 1) + 1) (x-y) \cdot \nu(y), \quad x, y \in \Gamma.$$

To bound $D_k - D_0$ the following auxiliary result is useful.

Lemma 3.4 *For $t \geq 0$, it holds that $|e^{it}(it - 1) + 1| \leq 2t$.*

Proof. If $t \geq 2$ then $|e^{it}(it - 1) + 1| \leq t + 2 \leq 2t$. If $0 < t < 2$ put $f(t) = e^{it}(it - 1)$ and note that

$$|e^{it}(it - 1) + 1| = |f(t) - f(0)| = \left| \int_0^t f'(s) ds \right| \leq \int_0^t |-se^{is}| ds = \frac{t^2}{2} \leq t. \quad \blacksquare$$

This lemma implies that $|\kappa(x, y)| \leq k(\pi|x-y|)^{-1}$, for $x, y \in \Gamma$, so that, by (3.4),

$$\|D_k - D_0\| \leq \frac{k}{\pi} \operatorname{ess\,sup}_{x \in \Gamma} \int_{\Gamma} \frac{ds(y)}{|x-y|} < \infty,$$

by Lemma 3.2, and consequently

$$\|D_k\| \leq \|D_k - D_0\| + \|D_0\| \leq C_3 k + C_4, \quad (3.11)$$

where

$$C_3 := \frac{1}{\pi} \operatorname{ess\,sup}_{x \in \Gamma} \int_{\Gamma} \frac{1}{|x - y|} ds(y) \quad \text{and} \quad C_4 := \|D_0\|.$$

We see that we have shown, in (3.10) and (3.11), the following theorem:

Theorem 3.5 *If Γ is Lipschitz then there exist positive constants c_1 and c_2 , dependent only on Γ , such that*

$$\|D_k\| \leq c_1 k^{(d-1)/2} + c_2$$

for $k > 0$.

Combining the bounds (3.5), (3.7), (3.10), (3.11), with (2.13), we see that we have shown the following result for the general Lipschitz case.

Theorem 3.6 *If Γ is Lipschitz then there exist positive constants c_1 and c_2 , dependent only on Γ , such that*

$$\|A_{k,\eta}\| \leq 1 + c_1 k^{(d-1)/2} + c_2 |\eta| k^{(d-3)/2}, \quad (3.12)$$

for all $k > 0$.

We note that in 2D ($d = 2$), for the case Γ simply-connected and smooth, this bound was shown previously, for all sufficiently large k , in [15].

4 Lower bounds

In this section, complementing the results of the previous section, we derive lower bounds on $\|S_k\|$, $\|D_k\|$, and $\|A_{k,\eta}\|$. We will focus mainly on the 2D case and our technique throughout will be one of choosing $\varphi_k \in L^2(\Gamma)$ (whose value depends on k) with the aim of maximising one of $\|S_k \varphi_k\|$, $\|D_k \varphi_k\|$, or $\|A_{k,\eta} \varphi_k\|$. Our first result is something of an exception in that we obtain lower bounds on both $\|A_{k,\eta}\|$ and its inverse, in both the 2D and 3D cases. This simple lemma follows from the fact that S_k and D_k are smoothing operators on smooth parts of Γ .

Lemma 4.1 *In both 2D and 3D, if a part of Γ is C^1 , then $\|A_{k,\eta}\| \geq 1$, $\|A_{k,\eta}^{-1}\| \geq 1$.*

Proof. Choose $x^* \in \Gamma$ such that Γ is C^1 in a neighbourhood of x^* . Let t^* be a unit tangent vector at x^* . For $\epsilon > 0$ let $\Gamma_\epsilon := \{x \in \Gamma : |x - x^*| < \epsilon\}$ and let χ_ϵ denote the characteristic function of Γ_ϵ , i.e. $\chi_\epsilon(x) := 1$, $x \in \Gamma_\epsilon$, $:= 0$ for $x \in \Gamma \setminus \Gamma_\epsilon$. For $\epsilon > 0$ and $n \in \mathbb{N}$ let $\phi_{n,\epsilon}(x) := \exp(inx \cdot t^*) \chi_\epsilon(x)$, $x \in \Gamma$. Then $\chi_\epsilon \in L^2(\Gamma)$ so that $\phi_{n,\epsilon} \in L^2(\Gamma)$ for all $n \in \mathbb{N}$. Further, if ϵ is small enough it is easy to see by the Riemann-Lebesgue lemma that $\phi_{n,\epsilon} \rightharpoonup 0$ as $n \rightarrow \infty$, where \rightharpoonup denotes weak convergence in $L^2(\Gamma)$. Moreover, for ϵ sufficiently small, the mappings $\phi \mapsto S_k \chi_\epsilon \phi$ and $\phi \mapsto D_k \chi_\epsilon \phi$, from $L^2(\Gamma)$ to $L^2(\Gamma)$, are compact operators, the first mapping since the kernel of S is weakly singular, the second due to a result of Fabes et al. [16] (that the double-layer

potential operator is a compact operator on the boundary of bounded C^1 domains). Since an operator B is a compact operator on a Hilbert space if and only if weakly convergent sequences are mapped to strongly convergent sequences, it follows, if ϵ is sufficiently small, that $\|S_k \phi_{n,\epsilon}\| = \|S_k \chi_\epsilon \phi_{n,\epsilon}\| \rightarrow 0$ and $\|D_k \phi_{n,\epsilon}\| = \|D_k \chi_\epsilon \phi_{n,\epsilon}\| \rightarrow 0$ as $n \rightarrow \infty$, so that $\|A_{k,\eta} \phi_{n,\epsilon}\| \rightarrow \|\phi_{n,\epsilon}\|$. Since $\|A_{k,\eta}^{-1}\|^{-1} \leq \|A_{k,\eta} \phi_{n,\epsilon}\| / \|\phi_{n,\epsilon}\| \leq \|A_{k,\eta}\|$, the result follows. \blacksquare

In the next two theorems we construct lower bounds which show that the upper bounds (3.5) and (3.10) are sharp in their dependence on k , in that there exist Lipschitz domains for which these bounds are achieved or arbitrarily closely achieved.

Theorem 4.2 *In the 2D case, if Γ contains a straight line section of length a , then*

$$\|S_k\| \geq \sqrt{\frac{a}{\pi k}} + O(k^{-1})$$

as $k \rightarrow \infty$ and

$$\|A_{k,\eta}\| \geq |\eta| \sqrt{\frac{a}{\pi k}} - 1 + O(|\eta|k^{-1})$$

as $k \rightarrow \infty$, uniformly in η .

Proof. Let $\tilde{\Gamma}$ be a straight line section of Γ of length a . Without loss of generality we can choose the axes Ox_1x_2 of the Cartesian coordinate system so that $\tilde{\Gamma} = \{(x_1, 0) : 0 \leq x_1 \leq a\}$. Define $\phi \in L^2(\Gamma)$ by $\phi(x) := \exp(ikx_1)$, $x_1 \in \tilde{\Gamma}$, $\phi(x) := 0$, otherwise. Then, defining $\psi := S_k \phi$ and $\tilde{\psi}(u) := \psi((u/k, 0))$, $0 \leq u \leq \kappa := ka$, it holds that

$$\|\psi\|^2 \geq \int_0^a |\psi((s, 0))|^2 ds = k^{-1} \int_0^\kappa |\tilde{\psi}(u)|^2 du.$$

Further, for $0 \leq u \leq \kappa$,

$$\begin{aligned} |\tilde{\psi}(u)| &= \frac{1}{2} \left| \int_0^a H_0^{(1)}(k|u/k - t|) e^{ikt} dt \right| \\ &= \frac{1}{2k} \left| \int_0^\kappa H_0^{(1)}(|u - v|) e^{iv} dv \right| \\ &= \frac{1}{2k} |\chi_1(u) + \chi_2(u)|, \end{aligned}$$

where, for $0 \leq u \leq \kappa$,

$$\chi_1(u) := \int_0^u H_0^{(1)}(u - v) e^{iv} dv, \quad \chi_2(u) := \int_u^\kappa H_0^{(1)}(v - u) e^{iv} dv.$$

Recalling that Ψ_0 is defined by (1.27), we have that

$$|\chi_1(u)| = \left| \int_0^u \Psi_0(u - v) dv \right| = \left| \int_0^u \Psi_0(v) dv \right|$$

and

$$|\chi_2(u)| = \left| \int_u^\kappa \Psi_0(v - u) e^{2iv} dv \right| = \left| \int_0^{\kappa - u} \Psi_0(v) e^{2iv} dv \right|.$$

Using (1.28), and integrating by parts in the case of χ_2 , we see that, as $k \rightarrow \infty$,

$$|\chi_1(u)| = 2\sqrt{\frac{2u}{\pi}} + O(1), \quad |\chi_2(u)| = O(1),$$

uniformly for $0 \leq u \leq \kappa$. Thus, uniformly for $0 \leq u \leq \kappa$,

$$\tilde{\psi}(u) = k^{-1}\sqrt{\frac{2u}{\pi}} + O(k^{-1})$$

so that

$$\|\psi\| \geq \left\{ \int_0^a |\psi((s, 0))|^2 ds \right\}^{1/2} = k^{-1/2} \left\{ \int_0^\kappa |\tilde{\psi}(u)|^2 du \right\}^{1/2} = \frac{a}{\sqrt{\pi k}} + O(k^{-1}).$$

It follows that

$$\|S_k\| \geq \frac{\|\psi\|}{\|\phi\|} = \sqrt{\frac{a}{\pi k}} + O(k^{-1}).$$

To obtain the lower bound on $A_{k,\eta}$, defining $\psi' := A_{k,\eta}\phi$, we see that $\psi'(x) = \phi(x) - i\eta\psi(x)$, for $x \in \tilde{\Gamma}$. Thus

$$\begin{aligned} \|A_{k,\eta}\| &\geq \frac{\|\psi'\|}{\|\phi\|} \geq \frac{\{\int_0^a |\psi'((s, 0))|^2 ds\}^{1/2}}{\|\phi\|} \\ &\geq \frac{|\eta|\{\int_0^a |\psi((s, 0))|^2 ds\}^{1/2}}{\|\phi\|} - 1 \\ &\geq |\eta|\sqrt{\frac{a}{\pi k}} - 1 + O(|\eta|k^{-1}). \end{aligned}$$

■

In the case that Γ is a straight line of length a , the lower bound on $\|S_k\|$ in the above theorem is particularly close to the upper bound (3.5)-(3.6) which predicts that

$$\|S_k\| \leq \sqrt{\frac{1}{2\pi k}} \sup_{0 \leq s \leq a} \int_0^a \frac{1}{\sqrt{|s-t|}} dt = \sqrt{\frac{2}{\pi k}} \int_0^{a/2} \frac{dt}{\sqrt{t}} = 2\sqrt{\frac{a}{\pi k}}.$$

Theorem 4.3 *In the 2D case, if $c : (0, \infty) \rightarrow (0, \infty)$ is such that $c(k) = o(k^{1/2})$ as $k \rightarrow \infty$, then there exists a Lipschitz Γ such that $\|D_k\| \geq c(k)$ for all sufficiently large k .*

Proof. It is convenient to first construct a function $\tilde{c} : (0, \infty) \rightarrow (0, \infty)$ which is continuously differentiable, satisfies $\tilde{c}(k) \geq c(k)$ for all sufficiently large k , and is such that $g(k) := \tilde{c}(k)k^{-1/2}$ is strictly decreasing on $(0, \infty)$, with $g(k) \rightarrow \infty$ as $k \rightarrow 0$ and $g(k) \rightarrow 0$, $g'(k) \rightarrow 0$ as $k \rightarrow \infty$, so that g is a diffeomorphism on $(0, \infty)$, whose inverse we will denote by g^{-1} . Then the proof is completed by showing that $\|D_k\| \geq \tilde{c}(k)$ for all sufficiently large k .

To achieve this construction, we first define $g_1 : [0, \infty) \rightarrow (0, \infty)$ by $g_1(k) := 1$, $0 < k \leq 1$ and

$$g_1(k) := \min \left(1, \sup_{s \geq k} \frac{c(s)}{s^{1/2}} \right), \quad k > 1.$$

We see that g_1 is decreasing and so measurable and that $g_1(k) \geq c(k)/k^{1/2}$ for all sufficiently large k . Next define $g_2 : [0, \infty) \rightarrow (0, \infty)$ by $g_2(k) := 1$, $0 < k \leq 1$ and $g_2(k) := \int_{k-1}^k g_1(s) ds$, $k > 1$. Clearly g_2 is decreasing and continuous and $g_2(k) \geq g_1(k)$, $k > 0$. Now, define $a_n := \min\{k \geq 0 : g_2(k) \leq 1/n\}$, $n \in \mathbb{N}$, so that $0 = a_1 < a_2 < \dots$, and define $g_3 : [0, \infty) \rightarrow (0, \infty)$ by the requirement that $g_3(a_n) = 2/n$, $n \in \mathbb{N}$, and that g_3 is linear on $[a_n, a_{n+1}]$, for each n . Then g_3 is strictly decreasing, $g_3(k) \rightarrow 0$ as $k \rightarrow \infty$, and, for $n \in \mathbb{N}$ and $k \in [a_n, a_{n+1}]$,

$$g_3(k) > g_3(a_{n+1}) = 2(n+1)^{-1} \geq n^{-1} = g_2(a_n) \geq g_2(k) \geq g_1(k).$$

Next, defining $g_4 : (0, \infty) \rightarrow (0, \infty)$ by

$$g_4(k) := \begin{cases} g_3(1)k^{-1}, & 0 < k < 1, \\ g_3(k), & k > 1, \end{cases}$$

we see that g_4 is strictly decreasing and continuous. Finally, defining $g : (0, \infty) \rightarrow (0, \infty)$ by

$$g(k) := \frac{2}{k} \int_{k/2}^k g_4(s) ds, \quad k > 0,$$

we see that

$$g(k) \geq g_4(k) \geq g_1(k) \geq \frac{c(k)}{k^{1/2}}$$

for all sufficiently large k , so that $g(k) \rightarrow 0$ as $k \rightarrow 0$ and $\tilde{c}(k) := k^{1/2}g(k) \geq c(k)$. Further, g is continuously differentiable with

$$\begin{aligned} g'(k) &= -\frac{2}{k^2} \int_{k/2}^k g_4(s) ds + \frac{2}{k} g_4(k) - \frac{1}{k} g_4\left(\frac{k}{2}\right) \\ &\leq -\frac{2}{k^2} \frac{k}{2} g_4(k) + \frac{2}{k} g_4(k) - \frac{1}{k} g_4\left(\frac{k}{2}\right) \\ &= \frac{1}{k} \left(g_4(k) - g_4\left(\frac{k}{2}\right) \right) < 0, \end{aligned}$$

and, for $k > 2$, $g(k) \leq g_4(k/2) = g_3(k/2) \rightarrow 0$ as $k \rightarrow \infty$, so that also $g'(k) \rightarrow 0$ as $k \rightarrow \infty$.

To proceed with the remainder of the proof, define $\tilde{f} \in C^1(\mathbb{R})$ by

$$\tilde{f}(s) := \begin{cases} 0, & s \leq 0, \\ [g^{-1}(\sqrt{s})]^{-1/2} s, & s > 0. \end{cases}$$

Note that, with this definition, $\tilde{f}(s)$ is strictly increasing as s increases for $s > 0$. Further, since, as $s \rightarrow 0^+$, $g^{-1}(s) \rightarrow \infty$ and $g^{-1}(s) = [g'(g^{-1}(s))]^{-1} \rightarrow 0$, it follows that $\tilde{f}(s) = o(s)$ and $\tilde{f}'(s) \rightarrow 0$ as $s \rightarrow 0^+$ (so that $\tilde{f} \in C^1(\mathbb{R})$). Next choose $f \in C^{0,1}(\mathbb{R})$ so that $0 \leq f(s) \leq \tilde{f}(s)$, for $s \in \mathbb{R}$, and so that, for some $a > 0$ and $L > 4\sqrt{2}\pi$, $f(s) = 0$ for $s \geq a$ and $|f'(s)| = L$ for all but a finite set of values of s in $(0, a)$. For example, this can be achieved by choosing a so that $0 \leq f'(s) \leq L$ on $(0, a)$, and then constructing the graph of f on the interval $(0, a)$ by drawing a line with gradient $-L$ up from the point $(a, 0)$ until it meets the graph of \tilde{f} , then drawing

a line of gradient L from this intersection point to the x -axis at some point $(0, a_1)$, then repeating this construction ad infinitum. Let $\tilde{\Gamma} := \{(s, f(s)) : -a \leq s \leq a\}$, and choose Γ so that it is Lipschitz and contains $\tilde{\Gamma}$ (e.g. form Γ by joining the two ends of $\tilde{\Gamma}$ at $(\pm a, 0)$ by a smooth arc, tangential to the x -axis at $(\pm a, 0)$).

Having constructed Γ in this way, choose ϵ so that $0 < \epsilon < a$ and define $\phi \in L^2(\Gamma)$ by $\phi(x) = \exp(-ikx_1)$, if $x \in \tilde{\Gamma}$ and $0 \leq x_1 \leq \epsilon$, $= 0$, otherwise, and let $\psi = D_k \phi$. Then for $x \in \tilde{\Gamma}$ with $-a \leq x_1 \leq -a/2$ it follows from (3.8) that

$$|\psi(x)| = \frac{k}{2} \left| \int_0^\epsilon H_1^{(1)}(k\sqrt{(x_1-t)^2 + (f(t))^2}) \frac{f(t) + (x_1-t)f'(t)}{\sqrt{(x_1-t)^2 + (f(t))^2}} e^{-ikt} dt \right|.$$

Now, choosing ϵ dependent on k so that $\epsilon \rightarrow 0$ as $k \rightarrow \infty$, we see using (1.25) that

$$|\psi(x)| = \frac{Lk}{2} \sqrt{\frac{2}{\pi k}} (-x_1)^{-1/2} \left| \int_0^\epsilon \exp(ik(\sqrt{(x_1-t)^2 + (f(t))^2} + (x_1-t))) dt \right| + O(\epsilon k^{-1/2}) + o(\epsilon^2 k^{1/2})$$

as $k \rightarrow \infty$, uniformly for $-a \leq x_1 \leq -a/2$. Now, for $-a \leq x_1 \leq -a/2$, $0 \leq t \leq \epsilon$,

$$\begin{aligned} 0 &\leq \sqrt{(x_1-t)^2 + (f(t))^2} + (x_1-t) \\ &= \frac{(f(t))^2}{\sqrt{(x_1-t)^2 + (f(t))^2} - (x_1-t)} \leq \frac{(f(t))^2}{2(t-x_1)} \leq \frac{(\tilde{f}(\epsilon))^2}{a}. \end{aligned}$$

Choosing ϵ so that $\epsilon = (g(k))^2$ for all sufficiently large k , we see that $k(\tilde{f}(\epsilon))^2 = \epsilon^2 \rightarrow 0$ as $k \rightarrow \infty$. Thus, for every $0 < \theta < 1$ it holds for $-a \leq x_1 \leq -a/2$ and all sufficiently large k that

$$|\psi(x)| \geq \frac{L\theta k^{1/2} \epsilon}{\sqrt{2\pi(-x_1)}} \geq \frac{L\theta}{\sqrt{2\pi a}} k^{1/2} (g(k))^2$$

so that

$$\|\psi\|_2 \geq \frac{L\theta}{\sqrt{2\pi a}} k^{1/2} (g(k))^2 \sqrt{\frac{a}{2}} = \frac{L\theta}{2\sqrt{\pi}} k^{1/2} (g(k))^2.$$

Since $\|\phi\|_2 = (1 + L^2)^{1/4} \epsilon^{1/2}$, it follows that, for all sufficiently large k ,

$$\|D_k\| \geq \frac{\|\psi\|_2}{\|\phi\|_2} \geq \frac{L\theta k^{1/2}}{2\sqrt{\pi}(1 + L^2)^{1/4}} g(k) \geq \frac{L^{1/2} \theta \tilde{c}(k)}{2\sqrt{\pi} 2^{1/4}}.$$

Choosing $\theta = 2\sqrt{\pi} 2^{1/4} / L^{1/2}$ which is < 1 since $L > 4\sqrt{2\pi}$, we see that we have shown that $\|D_k\| \geq \tilde{c}(k)$. \blacksquare

The construction in the proof of Theorem 4.2 can be adapted to obtain the lower bounds on $\|S_k\|$ and $\|A_{k,\eta}\|$ in the next theorem.

Theorem 4.4 *Suppose (in the 2D case) that Γ is locally C^2 in a neighbourhood of some point x^* on the boundary. Then, for some constants $C > 0$ and $k_0 > 0$ it holds for all $k \geq k_0$ and all $\eta \in \mathbb{R}$ that*

$$\|S_k\| \geq Ck^{-2/3} \quad \text{and} \quad \|A_{k,\eta}\| \geq C|\eta|k^{-2/3}.$$

More generally, adopt a local coordinate system OX_1X_2 with origin at x^* and the X_1 axis in the tangential direction at x^* , so that, near x^* , Γ coincides with the curve $\{x^* + t^*X_1 + n^*f(X_1) : X_1 \in \mathbb{R}\}$, for some $f \in C^2(\mathbb{R})$ with $f(0) = f'(0) = 0$; here t^* and n^* are the unit tangent and normal vectors at x^* . Then if, for some $N \in \mathbb{N}$, Γ is locally C^{N+1} near x^* , i.e. $f \in C^{N+1}(\mathbb{R})$, and if also $f'(0) = f^{(2)}(0) = \dots = f^{(N)}(0) = 0$, then there exist $C > 0$ and $k_0 > 0$ such that

$$\|S_k\| \geq Ck^{-(N+1)/(2N+1)} \quad \text{and} \quad \|A_{k,\eta}\| \geq C|\eta|k^{-(N+1)/(2N+1)}$$

for all $k \geq k_0$ and all $\eta \in \mathbb{R}$.

Proof. We adopt the local coordinate system OX_1X_2 , choose $\beta \in (0, 1)$, set $\alpha = 1 - \beta^2$, and suppose that $f \in C^{N+1}(\mathbb{R})$ with $f'(0) = \dots = f^{(N)}(0) = 0$. Then, for all ϵ sufficiently small, it holds that $\Gamma_{\pm} \subset \Gamma$, where $\Gamma_- := \{x^* + t^*X_1 + n^*f(X_1) : -\epsilon < X_1 < 0\}$ and $\Gamma_+ := \{x^* + t^*X_1 + n^*f(X_1) : \alpha\epsilon < X_1 < \epsilon\}$. Let $\phi(y) := \exp(iky \cdot t^*)$, for $y \in \Gamma_-$, $:= 0$, otherwise. Then, for all ϵ sufficiently small, it holds for $x = x^* + t^*s + n^*f(s) \in \Gamma_+$ that

$$|S_k\phi(x)| = \frac{1}{2} \left| \int_{-\epsilon}^0 H_0^{(1)} \left(k\sqrt{(s-t)^2 + (f(s) - f(t))^2} \right) e^{ikt} W(t) dt \right|,$$

where $W(t) := \sqrt{1 + (f'(t))^2}$. Defining $F(z) = \frac{1}{2} \exp(i\pi/4)\Psi_0(z)$, where Ψ_0 is as defined at the end of §1, we have

$$|S_k\phi(x)| = \left| \int_{-\epsilon}^0 \exp(ikg(s,t) - \pi/4) F(k(s-t)w(s,t)) W(t) dt \right|,$$

where

$$w(s,t) := \sqrt{1 + \frac{(f(s) - f(t))^2}{(s-t)^2}}$$

and $g(s,t) := (s-t)(w(s,t) - 1)$. Now, by Taylor's theorem, for $|r| \leq \epsilon$,

$$f'(r) = \frac{r^N}{N!} f^{(N+1)}(\xi),$$

for some ξ between 0 and r , so that, for $-\epsilon \leq t \leq 0$, $0 \leq s \leq \epsilon$,

$$|f'(r)| = \left| \int_t^s f'(r) dr \right| \leq |s-t| \epsilon^N M_{N,\epsilon},$$

where

$$M_{N,\epsilon} := \max_{-\epsilon \leq \xi \leq \epsilon} \frac{|f^{(N+1)}(\xi)|}{N!}.$$

Thus

$$0 \leq \frac{(f(s) - f(t))^2}{(s-t)^2} \leq \epsilon^{2N} M_{N,\epsilon}^2,$$

and so

$$0 \leq g(s,t) \leq 2\epsilon \left[\sqrt{1 + \epsilon^{2N} M_{N,\epsilon}^2} - 1 \right] \leq \epsilon^{2N+1} M_{N,\epsilon}^2.$$

Now choose $\theta > 0$ and

$$\epsilon = \left(\frac{\pi}{2k(M_{N,0} + \theta/N!)^2} \right)^{1/(2N+1)}.$$

Then, for all k sufficiently large, it holds that

$$M_{N,\epsilon} \leq M_{N,0} + \theta/N!. \quad (4.1)$$

so that

$$0 \leq kg(s, t) \leq k\epsilon^{2N+1}(M_{N,\epsilon})^2 \leq \frac{\pi}{2}.$$

Thus, and using (1.28), we see that, uniformly for $x \in \Gamma_+$ (i.e. for $\alpha\epsilon \leq s \leq \epsilon$),

$$\begin{aligned} |S_k\phi(x)| &= \sqrt{\frac{1}{2\pi}} \left| \int_{-\epsilon}^0 \frac{\exp(i[kg(s, t) - \pi/4])}{(k(s-t))^{1/2}} W(t) dt \right| + O(\epsilon(k\epsilon)^{-3/2}) \\ &\geq \sqrt{\frac{1}{4\pi k\epsilon}} \int_{-\epsilon}^0 \cos(kg(s, t) - \pi/4) dt + O(\epsilon^{-1/2}k^{-3/2}) \\ &\geq \sqrt{\frac{1}{4\pi k\epsilon}} \epsilon \cos(\pi/4) + O(\epsilon^{-1/2}k^{-3/2}) \\ &= \sqrt{\frac{\epsilon}{8\pi k}} (1 + O(\epsilon^{-1}k^{-1})). \end{aligned}$$

Thus, as $k \rightarrow \infty$,

$$\|S_k\phi\|^2 \geq \int_{\Gamma_+} |S\phi|^2 ds \geq \frac{(1-\alpha)\epsilon^2}{8\pi k} (1 + o(1)) \quad (4.2)$$

while

$$\|\phi\|^2 = \int_{\Gamma_-} ds \sim \epsilon. \quad (4.3)$$

So, as $k \rightarrow \infty$,

$$\begin{aligned} \|S_k\| &\geq \frac{\|S\phi\|}{\|\phi\|} \geq \sqrt{\frac{(1-\alpha)\epsilon}{8\pi k}} (1 + o(1)) \\ &\geq \beta C_N(\theta) k^{-(N+1)/(2N+1)} (1 + o(1)), \end{aligned}$$

where

$$C_N(\theta) = \sqrt{\frac{1}{8\pi}} \left(\sqrt{\frac{\pi}{2}} \frac{N!}{|f^{(N+1)}(0)| + \theta} \right)^{1/(2N+1)}.$$

Since $\theta > 0$ and $\beta \in (0, 1)$ are arbitrary, it follows in the case $f^{(N+1)}(0) = 0$ that $\|S_k\| k^{(N+1)/(2N+1)} \rightarrow \infty$ as $k \rightarrow \infty$ while, in the case that $f^{(N+1)}(0) \neq 0$,

$$\|S_k\| \geq C_N(0) k^{-(N+1)/(2N+1)} (1 + o(1)). \quad (4.4)$$

The above gives the lower bound on $\|S_k\|$. To obtain the lower bound on $\|A_{k,\eta}\|$ we observe that, for all ϵ sufficiently small, it holds for $x = x^* + t^*s + n^*f(s) \in \Gamma_+$ that

$$|D_k\phi(x)| \leq \frac{k}{2} \int_{-\epsilon}^0 \frac{|H_1^{(1)}(k(s-t)w(s, t))|}{(s-t)w(s, t)} |v(s, t)| W(t) dt,$$

where

$$|v(s, t)| = |f(s) - f(t) - (s - t)f'(t)| = \frac{(s - t)^2}{2} |f''(\xi)|,$$

for some ξ between s and t , so that $|\xi| \leq \epsilon$. Applying Taylor's theorem again, we see that

$$|v(s - t)| \leq \frac{(s - t)^2}{2} NM_{N, \epsilon} \epsilon^{N-1}.$$

Noting also the bound (1.23), we see that

$$|D_k \phi(x)| \leq \frac{kNM_{N, \epsilon} \epsilon^{N-1}}{2} \int_{-\epsilon}^0 \left(\frac{1}{\pi k} + \sqrt{\frac{s-t}{2\pi k}} \right) W(t) dt \leq \frac{NM_{N, \epsilon} \epsilon^N}{2\pi} \left(1 + \sqrt{\epsilon k \pi} \right) (1 + o(1)),$$

as $k \rightarrow \infty$, uniformly for $x \in \Gamma_+$. Thus, where $\|\cdot\|_+ = \left\{ \int_{\Gamma_+} |\cdot|^2 ds \right\}^{1/2}$ is a shorthand for the L^2 norm on Γ_+ ,

$$\|D_k \phi\|_+ \leq \frac{\beta NM_{N, \epsilon} \epsilon^{N+1/2}}{2\pi} \left(1 + \sqrt{\epsilon k \pi} \right) (1 + o(1)).$$

From this inequality, (4.2), and (4.3), and recalling that $\phi = 0$ on Γ_+ , it follows that

$$\begin{aligned} \|A_{k, \eta}\| &\geq \frac{\|A_{k, \eta} \phi\|}{\|\phi\|} \\ &\geq \frac{\|D_k \phi - i\eta S_k \phi\|_+}{\|\phi\|} \\ &\geq |\eta| \beta C_N(\theta) k^{-(N+1)/(2N+1)} (1 + o(1)) \\ &\quad - \frac{\beta NM_{N, \epsilon} \epsilon^N}{2\pi} \left(1 + \sqrt{\epsilon k \pi} \right) (1 + o(1)) \\ &\geq |\eta| \beta C_N(\theta) k^{-(N+1)/(2N+1)} (1 + o(1)) - \frac{\beta N}{2\sqrt{2}} (1 + o(1)), \end{aligned}$$

where to get this last inequality we use (4.1) and the definition of ϵ . Recalling that $\theta > 0$ and $\beta \in (0, 1)$ are arbitrary, we see that:

(i) if $f^{(N+1)}(0) = 0$ and $|\eta| \gtrsim k^{(N+1)/(2N+1)}$, then $\|A_{k, \eta}\| \rightarrow \infty$ and $\|A_{k, \eta}\| k^{(N+1)/(2N+1)} / |\eta| \rightarrow \infty$ as $k \rightarrow \infty$;

(ii) if $f^{(N+1)}(0) \neq 0$ and $|\eta| k^{-(N+1)/(2N+1)} \rightarrow \infty$, then

$$\|A_{k, \eta}\| \geq |\eta| C_N(0) k^{-(N+1)/(2N+1)} (1 + o(1)), \quad (4.5)$$

as $k \rightarrow \infty$;

(iii) if $f^{(N+1)}(0) \neq 0$ and $|\eta| \approx k^{(N+1)/(2N+1)}$, then

$$\|A_{k, \eta}\| \geq |\eta| C_N(0) k^{-(N+1)/(2N+1)} - \frac{N}{2\sqrt{2}} + o(1), \quad (4.6)$$

as $k \rightarrow \infty$. ■

We note that the bound (4.4) in fact gives a quantitative lower bound on $\|S_k\|$ in the limit $k \rightarrow \infty$. Similarly, (4.5) and (4.6) are quantitative lower bounds on $\|A_{k, \eta}\|$. Noting that $f''(0)$ is the curvature at x^* , we have, for example, the following corollary by applying these equations with $N = 1$.

Corollary 4.5 *Suppose (in the 2D case) that Γ is locally C^2 in a neighbourhood of some point x^* on the boundary and let R be the radius of curvature at x^* . If $R = \infty$, then $\|S_k\|k^{2/3} \rightarrow \infty$; if also, for some constant $C > 0$, $|\eta| \geq Ck^{2/3}$, then $\|A_{k,\eta}\| \rightarrow \infty$ and $\|A_{k,\eta}\|k^{2/3}/|\eta| \rightarrow \infty$ as $k \rightarrow \infty$. If $R < \infty$, then, as $k \rightarrow \infty$,*

$$\|S_k\| \geq \frac{1}{2} \left(\frac{R}{\pi} \right)^{1/3} (2k)^{-2/3} (1 + o(1)). \quad (4.7)$$

If $R < \infty$ and $|\eta|k^{-2/3} \rightarrow \infty$ as $k \rightarrow \infty$, then

$$\|A_{k,\eta}\| \geq \frac{|\eta|}{2} \left(\frac{R}{\pi} \right)^{1/3} (2k)^{-2/3} (1 + o(1)),$$

while, if $|\eta| \approx k^{2/3}$, then

$$\|A_{k,\eta}\| \geq \frac{|\eta|}{2} \left(\frac{R}{\pi} \right)^{1/3} (2k)^{-2/3} - \frac{1}{2\sqrt{2}} + o(1).$$

Note that the upper bound (2.12) on $\|S_k\|$ (which holds for a circle as well as for a sphere [15]) shows that the lower bound on $\|S_k\|$ implied by Theorem 4.4 in the case of a circle is sharp in its dependence on k . It follows from (3.5) that the lower bound implied by Theorem 4.4 is sharp in its dependence on k also in the limit $N \rightarrow \infty$ when $k^{-(N+1)/(2N+1)} \rightarrow k^{-1/2}$.

The next two theorems obtain lower bounds on $\|D_k\|$ by somewhat similar arguments. The conditions of Theorem 4.6 are satisfied, for example, if Γ is a polygon. (Choose x^1 to be a corner of the polygon and x^2 to be some point on an adjacent side.)

Theorem 4.6 *In the 2D case, suppose x^1 and x^2 are distinct points on Γ , that Γ is C^1 in one-sided neighbourhoods Γ^1 and Γ^2 of x^1 and x^2 , and that $(x^1 - x^2) \cdot \nu(x) = 0$ for $x \in \Gamma^2$ while $x^1 - x^2$ is not parallel to Γ^1 at x^1 . Then, for some constants $C > 0$ and $k_0 > 0$, it holds for all $k \geq k_0$ that $\|D_k\| \geq Ck^{1/4}$.*

Proof. We assume, without loss of generality, that the neighbourhoods Γ^1 and Γ^2 are chosen so that the distance between Γ^1 and Γ^2 is strictly positive. Let $\hat{u} := (x^2 - x^1)/|x^2 - x^1|$ and note that $(x - x^1)/|x - x^1| = \hat{u}$ for $x \in \Gamma^2$. Choose $\epsilon > 0$, define $\phi \in L^2(\Gamma)$ by $\phi(y) = \exp(-ik\hat{u} \cdot (x^1 - y))$ if $y \in \Gamma^1$ with $|x^1 - y| < \epsilon$, = 0 otherwise, and let $\psi = D_k\phi$. Let $\Gamma_\epsilon^1 = \{y \in \Gamma^1 : |y - x^1| < \epsilon\}$. Then it follows from (3.8) that

$$|\psi(x)| = \frac{k}{2} \left| \int_{\Gamma_\epsilon^1} H_1^{(1)}(k|x - y|) \frac{x - y}{|x - y|} \cdot \nu(y) e^{-ik\hat{u} \cdot (x^1 - y)} ds(y) \right|.$$

Choosing ϵ dependent on k so that $\epsilon \rightarrow 0$ as $k \rightarrow \infty$ we see, using (1.25), that, uniformly for $x \in \Gamma^2$,

$$\begin{aligned} |\psi(x)| &= \sqrt{\frac{k}{2\pi|x - x^1|}} |\hat{u} \cdot \nu(x^1)| \left| \int_{\Gamma_\epsilon^1} \exp(ik[|x - y| - \hat{u} \cdot (x^1 - y)]) ds(y) \right| \\ &\quad + o(k^{-1/2}) + o(\epsilon k^{1/2}) \end{aligned} \quad (4.8)$$

as $k \rightarrow \infty$. Now, uniformly for $x \in \Gamma^2$,

$$\begin{aligned} |x - y| &= |x - x^1| + \frac{x - x^1}{|x - x^1|} \cdot (x^1 - y) + O(\epsilon^2) \\ &= |x - x^1| + \hat{u} \cdot (x^1 - y) + O(\epsilon^2). \end{aligned}$$

Thus, choosing $\epsilon = ck^{-1/2}$ with $c > 0$ sufficiently small, we can ensure that, for all sufficiently large k ,

$$k \left| |x - y| - \hat{u} \cdot (x^1 - y) - |x - x^1| \right| \leq \frac{\pi}{4} \quad (4.9)$$

for $x \in \Gamma^2$, so that

$$\left| \int_{\Gamma_\epsilon^1} \exp(ik[|x - y| - \hat{u} \cdot (x^1 - y)]) ds(y) \right| \geq \frac{\epsilon}{\sqrt{2}} = \frac{ck^{-1/2}}{\sqrt{2}} \quad (4.10)$$

and

$$|\psi(x)| \geq \frac{c|\hat{u} \cdot \nu(x^1)|}{2\sqrt{\pi}|x - x^1|} + o(k^{-1/2}) \quad (4.11)$$

uniformly for $x \in \Gamma^2$ as $k \rightarrow \infty$. Thus, and since

$$\|\phi\|_2 = \left| \int_{\Gamma_\epsilon^1} ds(y) \right|^{1/2} = O(k^{1/4}) \quad (4.12)$$

we see that, for some constant $c > 0$,

$$\|D_k\| \geq \frac{\|\psi\|_2}{\|\phi\|_2} \geq ck^{1/4}$$

for all sufficiently large k . ■

The conditions of the first part of the next theorem are satisfied with $N = 0$ by some pair of points x^1 and x^2 whenever Γ is C^1 . Thus the theorem implies that if Γ is C^1 then, for some constant $C > 0$, $\|D_k\| \geq C$ for all sufficiently large k , a result which (cf. (2.12)) appears to be sharp in the case when Γ is a circle. Note also that, in the limit $N \rightarrow \infty$, the second part of the theorem recovers (almost) Theorem 4.6.

Theorem 4.7 *In the 2D case, suppose x^1 and x^2 are distinct points on Γ , and that, for some $N \in \mathbb{N}_0$, Γ is C^1 and C^{N+1} in one-sided neighbourhoods Γ^1 and Γ^2 of x^1 and x^2 , respectively, and that $x^1 - x^2$ is not parallel to Γ^1 at x^1 . Without loss of generality, choose Γ^2 so that, for some $\tilde{\epsilon} > 0$ and $f \in C^{N+1}(\mathbb{R})$ with $f(0) = 0$,*

$$\Gamma^2 = \{x^2 + t\hat{u} + f(t)\hat{n} : 0 \leq t \leq \tilde{\epsilon}\}$$

where $\hat{u} = (x^2 - x^1)/|x^1 - x^2|$ and \hat{n} are orthogonal unit vectors, and suppose that, for some $N \in \mathbb{N}_0$,

$$f^{(0)}(0) = f^{(1)}(0) = \dots = f^{(N)}(0) = 0. \quad (4.13)$$

Then there exist $C > 0$ and $k_0 > 0$ such that

$$\|D_k\| \geq Ck^{N/(4N+4)}$$

for all $k > k_0$.

Proof. Defining ϕ, Γ_ϵ^1 and ψ as in the proof of Theorem 4.6 and, without loss of generality, choosing $\tilde{\epsilon}$ and ϵ dependent on k so that $\tilde{\epsilon} \rightarrow 0$ and $\epsilon \rightarrow 0$ as $k \rightarrow \infty$, we see from (4.8) that, uniformly for $x \in \Gamma^2$,

$$|\psi(x)| = \sqrt{\frac{k}{2\pi|x^2 - x^1|}} |\hat{u} \cdot \nu(x^1)| \left| \int_{\Gamma_\epsilon^1} \exp(ik[|x - y| - \hat{u} \cdot (x^1 - y)]) ds(y) \right| + o(k^{-1/2}) + o(\epsilon k^{-1/2})$$

as $k \rightarrow \infty$. Further, uniformly for $x \in \Gamma^2$ and $y \in \Gamma_\epsilon^1$,

$$|x - y| = |x - x^1| + \frac{x - x^1}{|x - x^1|} \cdot (x^1 - y) + O(\epsilon^2)$$

as $k \rightarrow \infty$. Moreover, on Γ^2 , $x = x^2 + t\hat{u} + f(t)\hat{n}$, for some $t \in [0, \hat{\epsilon}]$, so that, where $g(t) := f(t)|x^2 - x^1|/(|x^2 - x^1| + t)$,

$$\frac{x - x^1}{|x - x^1|} = \frac{\hat{u} + g(t)\hat{n}}{|\hat{u} + g(t)\hat{n}|} = \frac{\hat{u} + g(t)\hat{n}}{\sqrt{1 + (g(t))^2}}.$$

It follows from (4.13) that $f(t) = O(t^{N+1})$ as $t \rightarrow 0$ so that $g(t) = O(t^{N+1})$ as $t \rightarrow 0$ and so

$$|x - y| = |x - x^1| + \hat{u} \cdot (x^1 - y) + O(\tilde{\epsilon}^{N+1}\epsilon) + O(\epsilon^2)$$

as $k \rightarrow \infty$. Thus, choosing $\epsilon = ck^{-1/2}$ and $\tilde{\epsilon} = \tilde{c}k^{-1/(2N+2)}$ with $c > 0$ and $\tilde{c} > 0$ sufficiently small, we can ensure that, for all sufficiently large k , (4.9) holds for $x \in \Gamma^2$, so that (4.10) and (4.11) hold uniformly for $x \in \Gamma^2$ as $k \rightarrow \infty$. Thus

$$\|\psi\|_2 \geq \frac{c}{2} \frac{|\hat{u} \cdot \nu(x^1)|}{\sqrt{\pi|x^2 - x^1|}} \tilde{\epsilon}^{1/2}$$

and, noting (4.12), we see that, for some constant $C > 0$,

$$\|D_k\| \geq \frac{\|\psi\|_2}{\|\phi\|_2} \geq Ck^{1/4}k^{-1/(4N+4)} = Ck^{N/(4N+4)},$$

for all sufficiently large k . ■

5 A lower bound on $\|A_{k,\eta}^{-1}\|$ for trapping domains

In this section we give an example of a Lipschitz domain Ω with boundary Γ for which $\|A_{k,\eta}^{-1}\|$ grows as $k \rightarrow \infty$, provided $|\eta| \leq Ck$ for some constant C . By Theorem 2.2 (which implies that $\|A_{k,\eta}^{-1}\| = O(1)$ as $k \rightarrow \infty$ if $|\eta| = k$), such a domain cannot be starlike in the sense of Assumption 2.1, and in particular cannot be convex. The precise rate of growth and the class of domain for which this growth rate is achieved are specified in the following theorem.

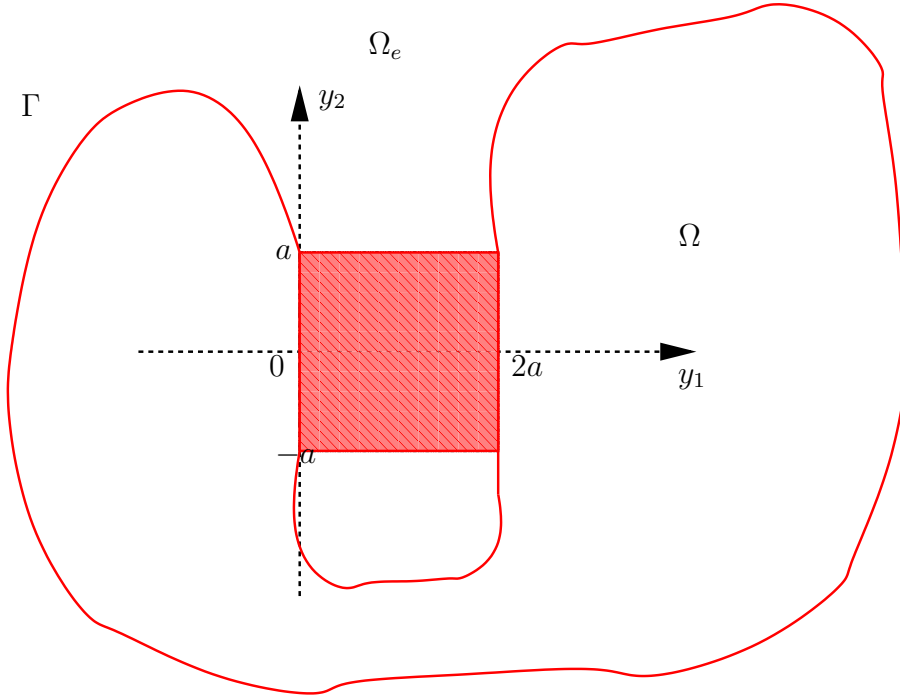

Figure 1: “Trapping” domain Ω_e is the exterior of the domain shown and contains the square $Q := [0, 2a] \times [-a, a]$

Theorem 5.1 *There exists $C > 0$ such that, if Γ is Lipschitz and Ω_e contains a square of side length $2a$, two parallel sides of which form part of Γ , and if $k = m\pi/2a$, for some positive integer m , and $\eta \in \mathbb{R} \setminus \{0\}$, then*

$$\|A_{k,\eta}^{-1}\| \geq C (ka)^{9/10} \left(1 + \frac{|\eta|}{k}\right)^{-1}. \quad (5.1)$$

The proof of the theorem is given below. It will depend on the following useful identity.

Lemma 5.2 *Suppose D is a Lipschitz domain in \mathbb{R}^2 with boundary ∂D . Then*

$$\begin{aligned} ik \int_D \exp(ik\phi(y)) f(y) dy &= \int_{\partial D} \frac{\partial \phi}{\partial n}(y) \frac{f(y)}{|\nabla \phi(y)|^2} \exp(ik\phi(y)) ds(y) \\ &\quad - \int_D \nabla \cdot \left[\frac{f(y)}{|\nabla \phi(y)|^2} \nabla \phi(y) \right] \exp(ik\phi(y)) dy, \end{aligned} \quad (5.2)$$

for all f and ϕ for which the right-hand side is finite.

Proof. By the divergence theorem,

$$\int_{\partial D} \frac{\partial \phi}{\partial n}(y) \frac{f(y)}{|\nabla \phi(y)|^2} \exp(ik\phi(y)) ds(y) = \int_D \nabla \cdot \left[\frac{f(y)}{|\nabla \phi(y)|^2} \nabla \phi(y) \exp(ik\phi(y)) \right] dy.$$

The required result follows by applying the product rule to the right-hand side. \blacksquare

Note that (5.2) appears in [20, §5] for the case when D is a simplex. There it is the starting point for asymptotic expansions of oscillatory integrals on multidimensional simplices. For that purpose a certain “non-resonance condition” on ϕ is imposed. However this condition is not required for the simpler case (of one integration by parts) which we consider here. Note that the requirement that the right-hand side of (5.2) is finite can typically be attained by requiring f and g to be sufficiently smooth and $\nabla\phi$ not to vanish on D (i.e. no stationary points of the oscillator ϕ).

Proof of Theorem 5.1. Throughout the proof we shall use the notation $A \lesssim B$ when A/B is bounded by a constant which is independent of m and independent of the quantity ϵ introduced in (5.21) below. In the case when A/B is also a function of position x on some part of Γ , we require that the constant be also independent of x . We write $A \sim B$ when $A \lesssim B$ and $B \lesssim A$. Note that the constraint on k that $2ka = m\pi$, for some $m \in \mathbb{N}$, implies that $ka \geq \pi/2 > 1$.

We shall construct specific $w, f \in L^2(\Gamma)$ such that

$$A'_{k,\eta} w = f, \quad (5.3)$$

$$\|w\| \gtrsim a^{1/2} k, \quad (5.4)$$

$$\|f\| \lesssim a^{-4/10} k^{1/10} (1 + |\eta|/k), \quad (5.5)$$

from which the result follows directly, on recalling that $\|A'^{-1}_{\eta,k}\| = \|A^{-1}_{\eta,k}\|$.

To construct w and f , without loss of generality we can assume that the square $Q := [0, 2a] \times [-a, a]$ is contained in Ω_e and that the sides $\{(0, x_2) : x_2 \in [-a, a]\}$ and $\{(2a, x_2) : x_2 \in [-a, a]\}$ form part of Γ (see Figure 1). Then consider the function u defined on Ω_e by

$$u(y) := \begin{cases} \sin(ky_1)F(y_2/a), & x \in Q, \\ 0, & x \in \Omega_e \setminus Q, \end{cases} \quad (5.6)$$

where $F(t) = (1 - t^2)^2$ (cf. [11]). Clearly u and ∇u are continuous on Ω_e and u satisfies

$$\Delta u + k^2 u = g \quad \text{on } \Omega_e, \quad (5.7)$$

$$\text{and (since } 2ka = m\pi) \quad u = 0 \quad \text{on } \Gamma, \quad (5.8)$$

where

$$g(y) = \begin{cases} a^{-2} \sin(ky_1)F''(y_2/a), & x \in Q, \\ 0, & x \in \Omega_e \setminus Q. \end{cases} \quad (5.9)$$

Moreover u clearly satisfies the Sommerfeld radiation condition in the far field.

Another solution of (5.7) which is valid in all of \mathbb{R}^2 and also satisfies the radiation condition is the Newtonian potential

$$u^N(x) := \int_{\mathbb{R}^2} \Phi(x, y) g(y) dy. \quad (5.10)$$

Since u^N also satisfies the homogeneous Helmholtz equation in the bounded domain Ω , we can write the relation between the Dirichlet and Neumann traces of u^N as

$$\begin{bmatrix} u^N \\ \partial u^N / \partial \nu \end{bmatrix} = \frac{1}{2} \begin{bmatrix} I - D_k & S_k \\ -H_k & I + D'_k \end{bmatrix} \begin{bmatrix} u^N \\ \partial u^N / \partial \nu \end{bmatrix}, \quad (5.11)$$

where H_k is the usual hypersingular operator on Γ . (The matrix on the right-hand side is usually called the Calderón projector. Note that its form is slightly different to usual since our operators D_k, S_k, H_k here contain a multiplicative factor of 2.)

Also, since $\tilde{u} := u - u^N$ satisfies the homogeneous Helmholtz equation in Ω_e together with the radiation condition, we have, analogously,

$$\begin{bmatrix} \tilde{u} \\ \partial\tilde{u}/\partial\nu \end{bmatrix} = \frac{1}{2} \begin{bmatrix} I + D_k & -S_k \\ H_k & I - D'_k \end{bmatrix} \begin{bmatrix} \tilde{u} \\ \partial\tilde{u}/\partial\nu \end{bmatrix}. \quad (5.12)$$

Thus, subtracting the first entries of each of (5.11) and (5.12) and using (5.8), we obtain

$$S_k \frac{\partial u}{\partial\nu} = 2u^N. \quad (5.13)$$

Similarly, subtracting the second entries of (5.11) and (5.12) yields

$$(I + D'_k) \frac{\partial u}{\partial\nu} = 2 \frac{\partial u^N}{\partial\nu}. \quad (5.14)$$

Hence, combining (5.13) (multiplied by $i\eta$) with (5.14) we obtain (5.3) with

$$w := \frac{\partial u}{\partial\nu} \quad \text{and} \quad f := 2 \left(\frac{\partial u^N}{\partial\nu} - i\eta u^N \right). \quad (5.15)$$

Now, to obtain (5.4), an easy calculation (recalling $2ka = m\pi$), shows

$$\|w\|^2 = 2 \int_{-a}^a k^2 |F(y_2/a)|^2 dy_2 \gtrsim ak^2. \quad (5.16)$$

To complete the proof we must prove (5.5) where f is given by (5.15). We begin this by estimating $\|u^N\|$. To do this we combine (5.10) and (5.9) to obtain, for $x \in \Gamma$,

$$u^N(x) = \sum_{j=1}^2 u_j^N(x), \quad \text{where} \quad u_j^N(x) = \int_Q \exp(ik\phi_j(x, y)) f_j(k, x, y) dy, \quad (5.17)$$

with $\phi_j(x, y) := |x - y| + (-1)^j y_1$,

$$f_j(k, x, y) := (-1)^j \frac{a^{-2}}{2i} F''(y_2/a) \Psi_0(k|x - y|),$$

and Ψ_0 defined by (1.27). We shall prove the required estimate for the oscillatory integral u_1^N (the case u_2^N is analogous). The phase function for u_1^N satisfies

$$\nabla\phi_1(x, y) = \frac{y - x}{|y - x|} - (1, 0)^T. \quad (5.18)$$

(Here and in the remainder of the proof, all differentiation is performed with respect to y .) To estimate $u_1^N(x)$ for $x \in \Gamma$, we distinguish three cases:

$$\left. \begin{array}{l} \text{(1)} \quad x_1 = 0 \quad \text{and} \quad x_2 \in [-a, a], \\ \text{(2)} \quad x_1 < 0 \quad \text{and} \quad x_2 \in [-a, a], \\ \text{(3)} \quad x_1 \geq 2a \quad \text{or} \quad x_2 \notin [-a, a]. \end{array} \right\} \quad (5.19)$$

It turns out that the dominant case is **(1)**. We analyse this in detail first and then explain briefly why cases **(2)** and **(3)** are less significant. In case **(1)**, ϕ_1 has a line of stationary points $\{(s, x_2) : s \in [0, 2a]\}$ in Q , with x at its left hand end (see Figure 2). Then, for any ϵ satisfying

$$k^{-1} \leq \epsilon \leq a, \quad (5.20)$$

we divide the square Q into a strip enclosing the stationary line,

$$Q_{x,\epsilon} := \{(s, x_2 + t) : s \in [0, 2a], t \in [-\epsilon, \epsilon]\} \cap Q, \quad (5.21)$$

and the remainder $\tilde{Q}_{x,\epsilon} := Q \setminus Q_{x,\epsilon}$. (Note that $\tilde{Q}_{x,\epsilon}$ consists of one rectangle if $x_2 < -a + \epsilon$ or $x_2 > a - \epsilon$ and two rectangles otherwise.) Then

$$\begin{aligned} u_1^N(x) &= \int_{Q_{x,\epsilon}} \exp(ik\phi_1(x, y)) f_1(k, x, y) dy + \int_{\tilde{Q}_{x,\epsilon}} \exp(ik\phi_1(x, y)) f_1(k, x, y) dy \\ &=: u_{1,\epsilon}^N(x) + \tilde{u}_{1,\epsilon}^N(x). \end{aligned} \quad (5.22)$$

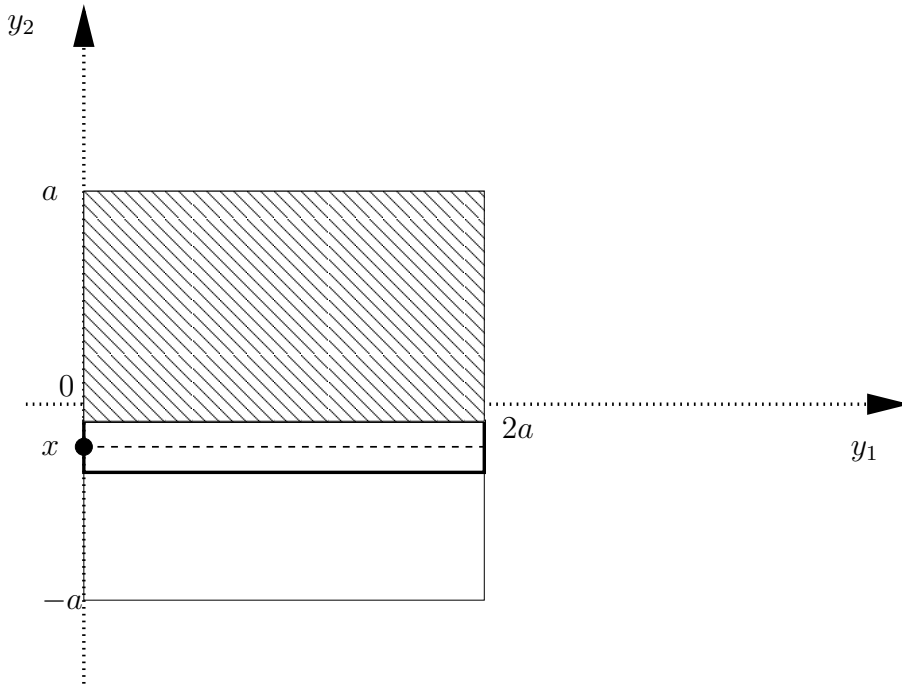

Figure 2: The square Q and the strip $Q_{x,\epsilon}$ where $x = (0, x_2) \in \Gamma$. The shaded area is a typical rectangle R .

Using the fact that M_0 satisfies the bound (1.22) we estimate $u_{1,\epsilon}^N(x)$ as follows:

$$\begin{aligned} |u_{1,\epsilon}^N(x)| &\leq a^{-2} \int_{Q_{x,\epsilon}} M_0(k|x-y|) |F''(y_2/a)| dy \\ &\lesssim a^{-2} k^{-1/2} \int_{Q_{x,\epsilon}} |x-y|^{-1/2} dy = a^{-2} k^{-1/2} \int_0^{2a} \int_{-\epsilon}^{\epsilon} (s^2 + t^2)^{-1/4} ds dt \\ &\leq a^{-2} k^{-1/2} \epsilon \int_0^{2a} t^{-1/2} dt \lesssim a^{-3/2} k^{-1/2} \epsilon. \end{aligned} \quad (5.23)$$

Turning to $\tilde{u}_{1,\epsilon}^N(x)$, without loss of generality consider the case when $\tilde{Q}_{x,\epsilon}$ consists of two rectangles and let R be the rectangle with $y_2 > x_2$. (That is the shaded rectangle in Figure 2.) Then, by Lemma 5.2,

$$\begin{aligned}
& ik \int_R \exp(ik\phi_1(x, y)) f_1(k, x, y) dy \\
&= \int_{\partial R} \frac{\partial \phi_1(x, y)}{\partial n(y)} \frac{f_1(k, x, y)}{|\nabla \phi_1(x, y)|^2} \exp(ik\phi_1(x, y)) ds(y) \\
&\quad - \int_R f_1(k, x, y) \frac{1}{|\nabla \phi_1(x, y)|^2} \Delta \phi_1(x, y) \exp(ik\phi_1(x, y)) dy \\
&\quad - \int_R f_1(k, x, y) \nabla \left(\frac{1}{|\nabla \phi_1(x, y)|^2} \right) \cdot \nabla \phi_1(x, y) \exp(ik\phi_1(x, y)) dy \\
&\quad - \int_R \frac{\nabla f_1(k, x, y) \cdot \nabla \phi_1(x, y)}{|\nabla \phi_1(x, y)|^2} \exp(ik\phi_1(x, y)) dy \\
&=: T1 + T2 + T3 + T4. \tag{5.24}
\end{aligned}$$

We estimate each term on the right-hand side of (5.24). First, by definition of $Q_{x,\epsilon}$, $|\nabla \phi_1(x, y)| \gtrsim a^{-1}\epsilon$, for $y \in Q_{x,\epsilon}$, and so, using the bound (1.22),

$$|T1| \lesssim a^{-1}\epsilon^{-1} \int_{\partial R} M_0(k|x-y|) ds(y) \lesssim a^{-1}\epsilon^{-1}k^{-1/2} \int_{\partial R} |y-x|^{-1/2} ds(y) \lesssim a^{-1/2}k^{-1/2}\epsilon^{-1}. \tag{5.25}$$

Next,

$$\begin{aligned}
|T4| &\lesssim a\epsilon^{-1} \int_R |\nabla f_1(k, x, y)| dy \\
&\lesssim a^{-1}\epsilon^{-1} \left\{ a^{-1} \int_R |F'''(y_2/a)| |\Psi_0(k|x-y|)| dy \right. \\
&\quad \left. + \int_R |F''(y_2/a)| |\nabla(\Psi_0(k|x-y|))| dy \right\} \\
&\lesssim a^{-1}\epsilon^{-1} \left\{ a^{-1} \int_R M_0(k|x-y|) dy + k \int_R |\Psi'_0(k|x-y|)| dy \right\} \\
&\lesssim a^{-1}\epsilon^{-1} \left\{ a^{-1}k^{-1/2} \int_R |x-y|^{-1/2} dy + k^{-1/2} \int_R |x-y|^{-3/2} dy \right\} \tag{5.26}
\end{aligned}$$

where to obtain this last line we use (1.22) and (1.28) and that $k|x-y| \geq k\epsilon \geq 1$ for $y \in R$. Now, taking polar coordinates about x and using (1.22), we obtain

$$\int_R |x-y|^{-1/2} dy \leq \int_0^{\pi/2} \int_\epsilon^{2\sqrt{2}a} r^{-1/2} r dr d\theta \lesssim a^{3/2}. \tag{5.27}$$

Similarly,

$$\int_R |x-y|^{-3/2} dy \lesssim a^{1/2}. \tag{5.28}$$

Combining the last two results with (5.26) we obtain for $T4$ the same estimate as for $T1$:

$$|T4| \lesssim a^{-1/2} k^{-1/2} \epsilon^{-1}. \quad (5.29)$$

The terms $T2$ and $T3$ need slightly more careful estimation. Recalling that we are dealing with Case **(1)**, so that $x = (0, x_2)$, and using formula (5.18), the following formulae are easily verified:

$$|\nabla\phi_1(x, y)|^2 = \frac{2}{|y - x|} (|y - x| - y_1), \quad (5.30)$$

and

$$\nabla \left(\frac{1}{|\nabla\phi_1(x, y)|^2} \right) \cdot \nabla\phi_1(x, y) = -\frac{1}{2|y - x|} \left(\frac{y_2 - x_2}{|y - x| - y_1} \right)^2. \quad (5.31)$$

Now consider the term $T2$. Note first that it follows easily from (5.18) that $\Delta\phi_1(x, y) = |y - x|^{-1}$ and hence, using (5.30) and (1.22), we have

$$\begin{aligned} |T2| &\lesssim \int_R |f_1(k, x, y)| \frac{1}{(|y - x| - y_1)} dy \\ &\leq a^{-2} \int_R M_0(k|x - y|) \frac{1}{(|y - x| - y_1)} dy \\ &\lesssim a^{-2} k^{-1/2} \epsilon^{-1/2} \int_R \frac{1}{(|y - x| - y_1)} dy. \end{aligned} \quad (5.32)$$

Then, rewriting (5.32) using polar coordinates centred at $x = (0, x_2)$, we obtain

$$\begin{aligned} |T2| &\lesssim a^{-2} k^{-1/2} \epsilon^{-1/2} \int_{\sin^{-1}(\epsilon/2a)}^{\pi/2} \int_0^{2\sqrt{2}a} \frac{1}{(r - r \cos \theta)} r dr d\theta \\ &\lesssim a^{-1} k^{-1/2} \epsilon^{-1/2} \int_{\sin^{-1}(\epsilon/2a)}^{\pi/2} \frac{1}{(1 - \cos \theta)} d\theta \\ &\lesssim a^{-1} k^{-1/2} \epsilon^{-1/2} \int_{\sin^{-1}(\epsilon/2a)}^{\pi/2} \theta^{-2} d\theta \lesssim k^{-1/2} \epsilon^{-3/2}. \end{aligned} \quad (5.33)$$

Finally, to estimate $T3$, we employ (5.31) and proceed as in (5.32)–(5.33) to obtain

$$\begin{aligned} |T3| &\lesssim a^{-2} k^{-1/2} \epsilon^{-1/2} \int_R \frac{1}{|y - x|} \left(\frac{y_2 - x_2}{|y - x| - y_1} \right)^2 dy \\ &= a^{-2} k^{-1/2} \epsilon^{-1/2} \int_{\sin^{-1}(\epsilon/2a)}^{\pi/2} \int_0^{2\sqrt{2}a} \frac{1}{r} \left(\frac{r \sin \theta}{r - r \cos \theta} \right)^2 r dr d\theta \\ &\lesssim a^{-1} k^{-1/2} \epsilon^{-1/2} \int_{\sin^{-1}(\epsilon/2a)}^{\pi/2} \theta^{-2} d\theta \sim k^{-1/2} \epsilon^{-3/2}. \end{aligned} \quad (5.34)$$

Combining the estimates (5.25), (5.29), (5.33), (5.34) with (5.24) and recalling that R is a typical rectangle in $\tilde{Q}_{x, \epsilon}$, we obtain

$$|\tilde{u}_{1, \epsilon}^N(x)| \lesssim k^{-3/2} \epsilon^{-3/2}. \quad (5.35)$$

Note also that the estimates in (5.25), (5.29) are smaller than those in (5.33), (5.34) but we have to use the worst of the four to get (5.35).

Now, choosing ϵ to equilibriate the estimates (5.35) and (5.23), we arrive at the choice $\epsilon = a^{3/5}k^{-2/5}$ (which also satisfies the requirement (5.20)) and yields the final estimate uniformly for x satisfying case **(1)**:

$$|u_1^N(x)| \lesssim a^{-9/10}k^{-9/10}. \quad (5.36)$$

It is not difficult to check that the same estimate holds also in case **(2)**. In this case ϕ_1 has the same line of stationary points as in case **(1)** and all the same manipulations hold to obtain the same bound uniformly for x satisfying case **(2)**. In case **(3)** the phase of the integrand of u_1^N has no stationary points. A similar argument can be applied if x is within a distance ϵ of R . If x is further away then Lemma 5.2 can be applied on all of Q yielding again the same estimate, uniformly for x satisfying case **(3)**. Therefore, since u_2^N is estimated using exactly the same argument, we obtain

$$\|u^N\| \lesssim a^{-4/10}k^{-9/10}. \quad (5.37)$$

We now consider $\partial u^N/\partial\nu$, for which the argument is very similar. First, mimicking (5.17), we write $(\partial u^N/\partial\nu)(x) = \sum_{j=1}^2 u_{\nu,j}^N(x)$, where

$$u_{\nu,j}^N(x) = \int_Q \exp(ik\phi_j(x,y))f_{\nu,j}(k,x,y)dy, \quad x \in \Gamma, \quad (5.38)$$

with ϕ_j defined as above,

$$f_{\nu,j}(k,x,y) := (-1)^j(a^{-2}k/2i)F''(y_2/a)\frac{(y-x)\cdot\nu(x)}{|y-x|}\Psi_1(k|x-y|),$$

and Ψ_1 defined by (1.27). Again without loss of generality it is sufficient to estimate $\|u_{\nu,1}^N\|$. The three cases (5.19) have again to be considered, but we discuss only case **(1)**. As before, define the decomposition $u_{\nu,1}^N = u_{\nu,1,\epsilon}^N + \tilde{u}_{\nu,1,\epsilon}^N$ by simply replacing f_1 by $f_{\nu,1}$ in (5.22). Let $U_\epsilon(x)$ denote the ball centred at x of radius ϵ . Recalling the bound (1.23) and that $k\epsilon \geq 1$ by (5.20), a variation on the argument in (5.23) yields

$$\begin{aligned} |u_{\nu,1,\epsilon}^N(x)| &\lesssim a^{-2}k \int_{Q_\epsilon} M_1(k|x-y|)dy \\ &= a^{-2}k \left\{ \int_{U_{2\epsilon}(x)} (k|x-y|)^{-1} dy + \int_{Q_\epsilon} (k|x-y|)^{-1/2} dy \right\} \\ &\lesssim a^{-2}\epsilon + a^{-3/2}\epsilon k^{1/2} \lesssim a^{-3/2}k^{1/2}\epsilon, \end{aligned} \quad (5.39)$$

where in the last step we used that $k\epsilon \geq 1$.

To estimate $\tilde{u}_{\nu,1,\epsilon}^N$, we replace f_1 by $f_{\nu,1}$ in (5.24) and, calling the corresponding terms $(T1)_\nu, \dots, (T4)_\nu$, we estimate each of these terms in turn. Firstly, using (1.23) and that and since $k|x-y| \geq k\epsilon \geq 1$ for $y \in R$,

$$|(T1)_\nu| \lesssim a^{-1}k\epsilon^{-1} \int_{\partial R} M_1(k|y-x|)ds(y) \lesssim a^{-1/2}k^{1/2}\epsilon^{-1}. \quad (5.40)$$

Next, analogously to (5.26), and using (1.23) and (1.28)), we have

$$\begin{aligned}
|(T4)_\nu| &\lesssim a\epsilon^{-1} \int_R |\nabla f_{\nu,1}(k, x, y)| dy \\
&\lesssim a^{-1}k\epsilon^{-1} \left\{ a^{-1} \int_R M_1(k|x-y|) dy + k \int_R |\Psi'_1(k|x-y|)| dy \right\} \\
&\lesssim a^{-1}k\epsilon^{-1} \left\{ a^{-1}[a^{3/2}k^{-1/2}] + k[a^{1/2}k^{-3/2}] \right\} \sim a^{-1/2}k^{1/2}\epsilon^{-1}. \quad (5.41)
\end{aligned}$$

Finally the estimates for $(T_2)_\nu$ and $(T_3)_\nu$ are easily achieved from the previous arguments. For $(T_2)_\nu$, follow (5.32) and (5.33) to obtain

$$\begin{aligned}
|(T2)_\nu| &\lesssim a^{-2}k \int_R |M_1(k|x-y|)| \frac{1}{(|y-x|-y_1)} dy \\
&\lesssim a^{-2}k^{1/2}\epsilon^{-1/2} \int_R \frac{1}{(|y-x|-y_1)} dy \lesssim k^{1/2}\epsilon^{-3/2}. \quad (5.42)
\end{aligned}$$

Similarly $|(T3)_\nu| \lesssim k^{1/2}\epsilon^{-3/2}$ and gathering all these estimates we obtain

$$|\tilde{u}_{\nu,1,\epsilon}^N(x)| \lesssim k^{-1/2}\epsilon^{-3/2}.$$

Comparing this with (5.39), we see that again the choice $\epsilon = a^{3/5}k^{-2/5}$ equilibrates the estimates, yielding $|u_{\nu,1}^N(x)| \lesssim a^{-9/10}k^{1/10}$, uniformly for $x \in \Gamma$, and, consequently,

$$\|\partial u^N / \partial \nu\| \lesssim a^{-4/10}k^{1/10}. \quad (5.43)$$

Combining (5.43) with (5.37) we obtain (5.5) and the proof is complete. ■

6 Bounds on $\text{cond } A_{k,\eta}$ and concluding remarks

In this section we summarise, in a convenient form for the reader, the theoretical results obtained in the previous sections, and explore their implications in terms of upper and lower bounds on the (identical) condition numbers of $A_{k,\eta}$ and $A'_{k,\eta}$. We remind the reader first of all that (1.17) and (1.18) hold so that $\text{cond } A'_{k,\eta} = \text{cond } A_{k,\eta} \geq \|A_{k,\eta} A_{k,\eta}^{-1}\| = 1$.

In the case of a **general Lipschitz domain** we have only the bound (3.12). For a **piecewise C^1 Lipschitz domain** we have also that Lemma 4.1 holds so that

$$1 \leq \|A_{k,\eta}\| \lesssim 1 + k^{(d-1)/2} + |\eta|k^{(d-3)/2}. \quad (6.1)$$

(In this section we write $A \lesssim B$ if, for some constant $c > 0$ dependent only on Ω , $A \leq cB$ for all $k > 0$, and write $A \sim B$ if $A \lesssim B$ and $B \lesssim A$.) In the case when Γ is **Lipschitz, piecewise C^2 and starlike**, satisfying Assumption 2.1, we have also, from Lemma 4.1 and Theorem 2.2, that

$$1 \leq \|A_{k,\eta}^{-1}\| \lesssim 1 + \frac{1+k}{|\eta|}. \quad (6.2)$$

Combining this equation with (6.1), we see that

$$1 \leq \text{cond } A_{k,\eta} \lesssim (1 + k^{(d-1)/2} + |\eta|k^{(d-3)/2}) \left(1 + \frac{1+k}{|\eta|}\right) \lesssim 1 + k^{(d-1)/2}, \quad (6.3)$$

if $|\eta| \sim 1 + k$ (e.g. if one chooses specifically η given by (2.17) or (2.19)).

The only other result we have for the 3D case ($d = 3$) is the bound (2.14) for the case of a sphere. Combining that bound with (6.1) and (6.2), we have **for the sphere** that

$$1 \leq \text{cond } A_{k,\eta} \lesssim (1 + |\eta|(1+k)^{-2/3}) \left(1 + \frac{1+k}{|\eta|}\right) \lesssim 1 + k^{1/3}, \quad (6.4)$$

if $|\eta| \sim 1 + k^p$, for some $p \in [\frac{2}{3}, 1]$.

We turn now specifically to the **2D case**, for which we have additionally the many lower bounds of §4. We note moreover that, adapting the arguments of §3 which show that $\|D_k - D_0\| \rightarrow 0$ as $k \rightarrow 0$, we can show that S_k depends continuously in norm on k for $k > 0$ and that, thanks to the asymptotic behaviour of $H_0^{(1)}$ for small argument, $\|S_k\| \rightarrow \infty$ logarithmically as $k \rightarrow 0$ (see [12] for more detail). Since also $S_k \neq 0$ for $k > 0$, it follows that $\|S_k\|$ is bounded below on $(0, k_0)$ for every $k_0 > 0$ while $\|D_k\|$ is bounded above by (3.10). These observations can be put together with the lower bounds for $k \rightarrow \infty$ in §4 to deduce lower bounds which hold for all $k > 0$. Specifically, for **the circle** it follows from these observations, (2.7), (3.5), (6.2), (2.7), and Corollary 4.5, that, for $\eta = k$,

$$1 + k^{1/3} \lesssim \|A_{k,\eta}\| \lesssim 1 + k^{-1/2} + k^{1/3}, \quad (6.5)$$

that $\|A_{k,\eta}^{-1}\| = 1$ for all sufficiently large k , and that

$$1 + k^{1/3} \lesssim \text{cond } A_{k,\eta} \lesssim 1 + k^{-1/2} + k^{1/3}. \quad (6.6)$$

For any 2D Lipschitz piecewise C^2 boundary², applying (6.1) and Corollary 4.5 we have

$$1 + |\eta|(1+k)^{-2/3} \lesssim \|A_{k,\eta}\| \lesssim 1 + k^{1/2} + |\eta|k^{-1/2}, \quad (6.7)$$

so that, **for any starlike 2D Lipschitz piecewise C^2 boundary** for which (6.2) also holds,

$$1 + |\eta|(1+k)^{-2/3} \lesssim \text{cond } A_{k,\eta} \lesssim (1 + k^{1/2} + |\eta|k^{-1/2}) \left(1 + \frac{1+k}{|\eta|}\right). \quad (6.8)$$

If Γ is not strictly convex, i.e. has zero curvature at some point on Γ , then the sharper lower bounds of Theorem 4.2 or 4.4 apply. For example, **if Γ is a polygon**, then, combining Theorem 4.2 with (6.1), we see that

$$1 + |\eta|(1+k)^{-1/2} \lesssim \|A_{k,\eta}\| \lesssim 1 + k^{1/2} + |\eta|k^{-1/2}. \quad (6.9)$$

²A 2D Lipschitz piecewise C^2 boundary is precisely a boundary Γ consisting of a finite number of C^2 arcs, with the corner angles where the arcs connect in the range $(0, 2\pi)$, so excluding cusps.

Thus, for a **starlike polygon**,

$$1 + |\eta|(1+k)^{-1/2} \lesssim \text{cond } A_{k,\eta} \lesssim (1 + k^{1/2} + |\eta|k^{-1/2}) \left(1 + \frac{1+k}{|\eta|}\right). \quad (6.10)$$

In particular, for $|\eta| \sim 1+k$,

$$1 + k^{1/2} \lesssim \text{cond } A_{k,\eta} \lesssim 1 + k^{-1/2} + k^{1/2}. \quad (6.11)$$

We finish this section by bounding the condition number for trapping obstacles that satisfy the conditions of Theorem 5.1 (see Figure 1). For such **trapping obstacles**, which contain two straight parallel sides, distance a apart, separated by the medium of propagation we have, from Theorem 4.2 and (6.1), that, if $k = m\pi/(2a)$ for some $m \in \mathbb{N}$, then

$$1 + |\eta|(1+k)^{-1/2} \lesssim \|A_{k,\eta}\| \lesssim 1 + k^{1/2} + |\eta|k^{-1/2}. \quad (6.12)$$

Thus, applying Theorem 5.1,

$$\text{cond } A_{k,\eta} \gtrsim (1 + |\eta|(1+k)^{-1/2})k^{9/10} \left(1 + \frac{|\eta|}{k}\right)^{-1}. \quad (6.13)$$

In particular, if $|\eta| \sim 1+k^p$, for some $p \geq 0$, then this bound implies that

$$\text{cond } A_{k,\eta} \gtrsim 1 + k^q, \quad (6.14)$$

with $q = 9/10$ for $0 \leq p \leq 1/2$, $q = p + 4/10$, for $1/2 \leq p \leq 1$, and $q = 14/10$ for $p \geq 1$, including for the usual choice $\eta \sim 1+k$.

In conclusion, we note that our results show that, asymptotically as $k \rightarrow \infty$, the conditioning of $A_{k,\eta}$ depends hugely on the geometry of Γ . In particular, for the usual choice $\eta \sim 1+k$, recommended e.g. in [18, 6], we have shown that $\text{cond } A_{k,\eta} \sim k^{1/3}$ as $k \rightarrow \infty$ for the case of a circle, $\text{cond } A_{k,\eta} \sim k^{1/2}$ for the case of a starlike polygon, while $\text{cond } A_{k,\eta} \gtrsim k^{14/10}$, for all sufficiently large k satisfying the condition $k = m\pi/(2a)$ for some $m \in \mathbb{N}$, when Γ is the boundary of a trapping obstacle satisfying the conditions of Theorem 5.1.

In [12] we investigate these trends in more detail, and show the same effects on the discrete level, when the boundary integral equations are discretised by a Galerkin boundary element method, applying a mixture of theoretical analysis and numerical experiment.

References

- [1] M. ABRAMOWITZ AND I. A. STEGUN, *Handbook of Mathematical Functions*, Dover, New York, 1972.
- [2] S. AMINI, *On the choice of the coupling parameter in boundary integral equation formulations of the exterior acoustic problem*, Appl. Anal., 35 (1990), pp. 75–92.
- [3] S. AMINI, *Boundary integral solution of the exterior acoustic problem*, Comput. Mech., (1993) pp. 2–11.

- [4] L. BANJAI and S. SAUTER, A refined Galerkin error and stability analysis for highly indefinite variational problems, *SIAM J. Numer. Anal.* 45 (2007) pp. 37–53.
- [5] H. BRAKHAGE AND P. WERNER, *Über das Dirichletsche Außenraumproblem für die Helmholtzsche Schwingungsgleichung*, *Arch. Math.*, 16 (1965), pp. 325–329.
- [6] O.P. BRUNO AND A.L. KUNYANSKY, *Surface scattering in three dimensions: an accelerated high-order solver*, *Proc. R. Soc. Lond. A* 457 (2001) pp. 2921–2934.
- [7] O.P. BRUNO, Private communication, 2007.
- [8] A. BUFFA AND S. SAUTER, *On the acoustic single layer potential: Stabilisation and Fourier analysis*, *SIAM J. Sci. Comput.* 28 (2006), pp. 1974–1999.
- [9] A.J. BURTON AND G.F. MILLER, *The application of integral equation methods for the numerical solution of boundary value problems*, *Proc. R. Soc. Lond. A* 232 (1971), pp. 201–210.
- [10] S. N. CHANDLER-WILDE AND S. LANGDON, *A Galerkin boundary element method for high frequency scattering by convex polygons*, *SIAM J. Numer. Anal.* 45 (2007), pp. 610–640.
- [11] S. N. CHANDLER-WILDE AND P. MONK, *Wave-number-explicit bounds in time-harmonic scattering*, *SIAM J. Math. Anal.* 39 (2008), pp. 1428–1455.
- [12] S. N. CHANDLER-WILDE, I. G. GRAHAM, S. LANGDON AND M. LINDNER, Condition number estimates for combined potential integral operators in acoustics and their boundary element discretisation, in preparation.
- [13] D. L. COLTON AND R. KRESS, *Integral equation methods in scattering theory*, John Wiley, New York, 1983.
- [14] ———, *Inverse Acoustic and Electromagnetic Scattering Theory*, Springer Verlag, 2nd Ed., 1992.
- [15] V. DOMINGUEZ, I. G. GRAHAM, AND V. P. SMYSHLYAEV, *A hybrid numerical-asymptotic boundary integral method for high-frequency acoustic scattering*, *Numer. Math.* 106 (2007), pp. 471–510.
- [16] E. B. FABES, M. JODEIT, AND N.M. RIVIERE, “Potential techniques for boundary value problems on C^1 domains”, *Acta Math.*, 141:165–186 (1978).
- [17] K. GIEBERMANN, *Schnelle Summationsverfahren zur numerischen Lösung von Integralgleichungen für Streuprobleme im \mathbb{R}^3* , PhD Thesis, Universität Karlsruhe, Germany, 1997.
- [18] R. KRESS, *Minimizing the condition number of boundary integral-operators in acoustic and electromagnetic scattering*, *Q. J. Mech. Appl. Math.*, 38 (1985), 323–341.

- [19] R. KRESS AND W. T. SPASSOV, *On the condition number of boundary integral operators for the exterior Dirichlet problem for the Helmholtz equation*, Numer. Math., 42 (1983), 77–95.
- [20] A. ISERLES AND S.P. NØRSETT, *Quadrature methods for multivariate highly oscillatory integrals using derivatives*. *Math. Comp.*, 75 (2006), pp. 1233–1258.
- [21] K. JÖRGENS, *Linear Integral Operators*, Pitman, Boston, 1982.
- [22] R. LEIS, *Zur Dirichletschen Randwertaufgabe des Aussenraums der Schwingungsgleichung*, Math. Z., 90 (1965), pp. 205–211.
- [23] J. LINDENSTRAUSS AND L. TZAFRIRI, *Classical Banach Spaces I*, Springer-Verlag, Berlin 1977.
- [24] W. MCLEAN, *Strongly Elliptic Systems and Boundary Integral Equations*, Cambridge University Press, 2000.
- [25] Y. MEYER AND R. COIFMAN, *Wavelets: Calderón-Zygmund and Multilinear Operators*, Cambridge University Press, 1997.
- [26] M. MITREA, *Boundary value problems and Hardy spaces associated to the Helmholtz equation in Lipschitz domains*, J. Math. Anal. Appl., 202 (1996), pp. 819–842.
- [27] F. OBERHETTINGER AND L. BADI, *Tables of Laplace Transforms*, Springer-Verlag, 1973.
- [28] O. I. PANIČ, *On the question of the solvability of the exterior boundary-value problems for the wave equation and Maxwell's equations*, Usp. Mat. Nauk, 20A (1965), pp. 221–226.
- [29] G. VERCHOTA, *Layer potentials and regularity for the Dirichlet problem for Laplace's equation in Lipschitz domains*, J. Funct. Anal., 59 (1984), pp. 572–611.
- [30] N. VALDIVIA, *Uniqueness in inverse obstacle scattering with conductive boundary conditions*, Appl. Anal. 83 (2004), pp. 825–851.
- [31] K.F. WARNICK AND W.C. CHEW, *Error analysis of the moment method*, IEEE Ant. Prop. Mag. 46 (2004), pp. 38–53.
- [32] K.F. WARNICK AND W.C. CHEW, *On the spectrum of the electric field integral equation and the convergence of the moment method*, Int. J. Numer. Meth. Engng. 51 (2001), pp. 31–56.
- [33] K.F. WARNICK AND W.C. CHEW, *Convergence of moment-method solutions of the electric field integral equation for a 2-D open cavity*, Microwave Optical Tech. Letters 23 (1999), pp. 212–218.
- [34] G. N. WATSON, *A Treatise on the Theory of Bessel Functions*, Cambridge University Press, 2nd Ed., 1944.